



YOSHIMURA

RESEARCH&DEVELOPMENT OF AMERICA, INC.

5420 DANIELS STREET STE A, CHINO CA., 91710 · (800) 634-9166 · (909) 628-4722 · FAX (909) 591-2198

www.yoshimura-rd.com

Street Series

Qualified Manufacturer Declared "Replacement Part"

2018
Triumph Street Triple
19680BP520 (SS/CF)

Alpha Taper Stainless Steel Slip-On

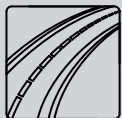

All Street Series systems are:

- Slip-on/Bolt-on applications that do not require tampering with the vehicle's emissions control system.
- CARB/EPA tail-pipe emissions compliant.
- Marked with appropriate EPA noise labels.
- Not tested for EPA new vehicle noise compliance.



✘ You must know how to remove and replace your stock exhaust in order to install this product otherwise have it installed by a professional mechanic. Keep all stock parts from your existing system as some components may be necessary to install your new Yoshimura exhaust depending on the application. Read through all instructions before beginning installation. Exhaust system can be extremely hot. Let motorcycle cool down before beginning installation. Always wear hand and eye protection and take precautionary measures to avoid injury. ✘

NOTE: IN THE STATE OF CALIFORNIA, IT IS ILLEGAL TO MODIFY THE EMISSION CONTROL SYSTEM, WHICH INCLUDES THE CARBURETORS OF ANY VEHICLE.

Assembly Diagram

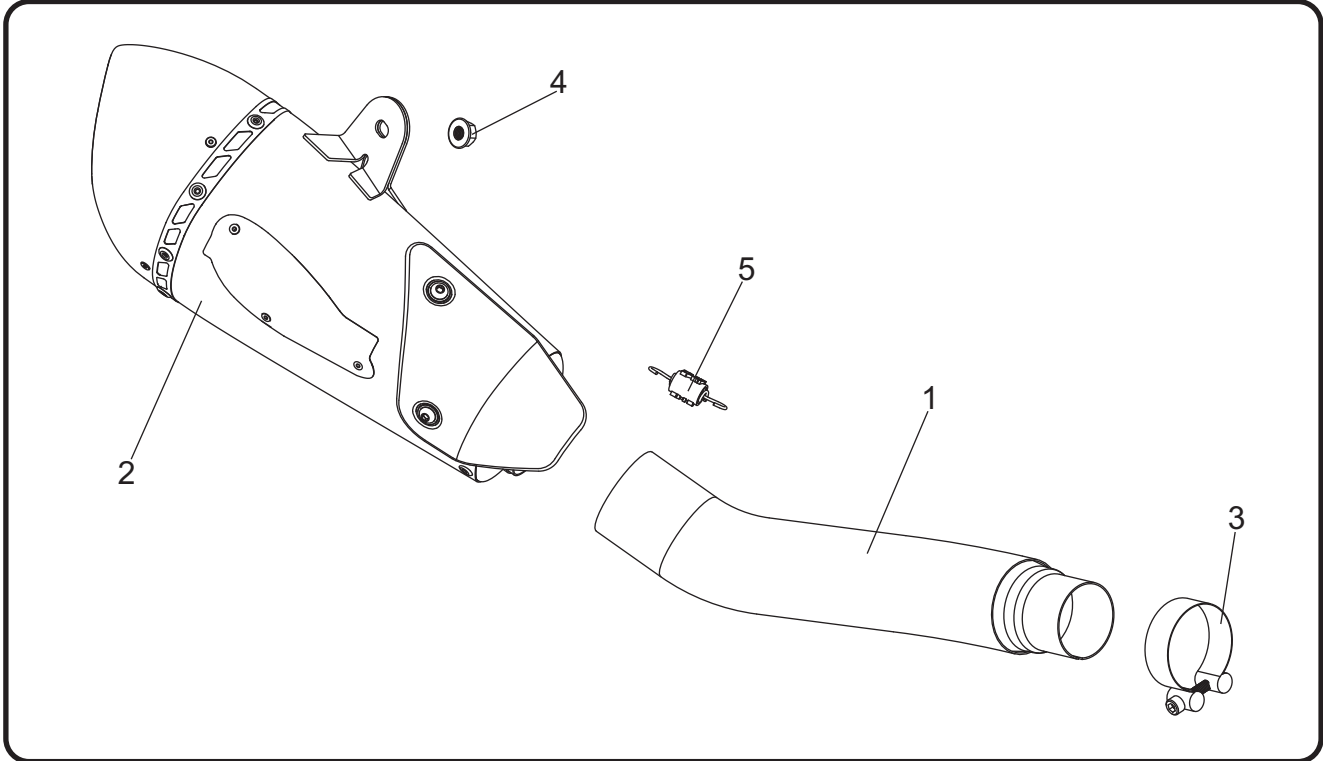

No.	Item	Description	Qty.
1	19680-435	Yoshimura Tailpipe	1
2	19680BP520-RMA	Yoshimura Muffler	1
3	27-61M	Exhaust Clamp	1
4	8MMNUT	8mm Flange Nut	1
5	RACE-SPX-1	Small Exhaust Spring	1
**	ST-200	Spring Puller Tool	1
**	INS-27-K	Low Volume Sound Insert	1
**	17029	Sticker Sheet	1

** Not Shown on diagram.

CAUTION: Exhaust system can be extremely hot. Let motorcycle cool down before beginning installation. Always wear hand and eye protection and take precautionary measures to avoid injury.

WARNING: Always properly support vehicle with a stand and/or lift when servicing or performing any work. Unstable vehicles may present dangerous conditions and may cause property damage and/or personal injury.

NOTE: Read through all instructions before beginning installation.

Removal

1. Remove muffler exhaust clamp nut.
2. While securely supporting the stock muffler assembly, remove the two muffler mount bolts and carefully remove the stock muffler assembly.

Note: The stock exhaust clamp, gasket, and header flanged sleeve will not be re-used.

Installation

1. Slide (No. 3) 27-61M, exhaust clamp over (No. 1) 19680-435, tailpipe inlet as shown. Do not torque clamp at this time.

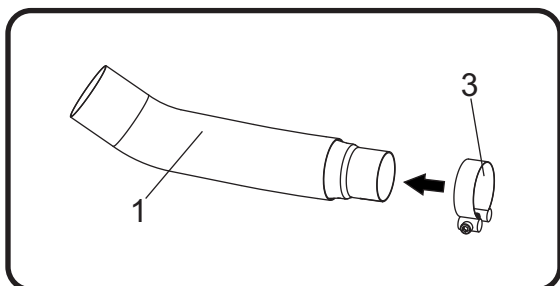

2. Install (No. 1) 19680-435, tailpipe outlet into (No. 2) 19680BP520-RMA, muffler inlet.
3. Install muffler/tailpipe assembly onto stock header outlet. Align muffler bracket to the backside of muffler mount and secure using the stock bolt, washer, and (No. 4) 8MMNUT, 8mm flange nut.

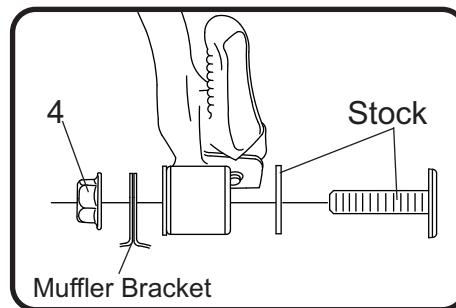

4. Torque muffler mount bolt to factory specification.
5. Install (No. 5) RACE-SPX-1, small exhaust spring between muffler and tailpipe using the ST-200, spring puller tool supplied in the kit.
6. Torque (No. 3) 27-61M, exhaust clamp to 8.5 Nm (0.86 kg-m, 6 ft-lbs).
7. Before starting vehicle, check for proper clearance between new exhaust system and rear suspension (i.e. tire, swingarm, brakes, rear shock, and etc.) If any problem is found, please carefully follow through the installation steps again. If problem still persists, please call Yoshimura Tech Department at (800) 634-9166 / in CA (909) 628-4722.
8. It is recommended that the muffler and tailpipe be wiped down with rubbing alcohol to remove oil and fingerprints. This will help prevent tarnishing of the finish after the exhaust is heated up.

Note: After starting motorcycle, it is normal for new exhaust system and muffler to emit smoke until oil residue burns off.

Works Finish Care & Maintenance

Before starting vehicle, clean pipe thoroughly using a soft cloth and rubbing alcohol to remove any oil and fingerprints.

The color of the exhaust will change once the system has gone through a heat cycle of 15 minutes or more. Color will vary depending on lean/rich conditions.

Clean using a soft cloth and soap. Do not use abrasive materials as it will scratch the surface.

Surface reconditioning services are available to remove scratches and undesirable discoloration due to extreme heat. Contact Yoshimura Tech Department at (800) 634-9166 / in CA (909) 628-4722 for more information.