



YOSHIMURA

RESEARCH&DEVELOPMENT OF AMERICA, INC.

5420 DANIELS STREET STE A, CHINO CA 91710 · (800) 634-9166 · (909) 628-4722 · FACSIMILE (909) 591-2198

WWW.YOSHIMURA-RD.COM

Signature Series

Qualified Manufacturer Declared "Replacement Part"

2014~2017

Yamaha YZ450F

234810D321 (AL/CF)

Stainless Steel RS4 Full-System



Signature Series systems are:

- CARB/EPA tail-pipe emissions compliant.
- Marked with appropriate EPA noise labels.
- Independent laboratory tested for EPA new vehicle noise compliance.



✘ CAUTION: The muffler packing on this system **MUST** be replaced every 6-8 hours of use, or after each moto. Failure to follow recommended muffler re-packing interval can cause muffler damage and may void the warranty. ✘

NOTE: IN THE STATE OF CALIFORNIA, IT IS ILLEGAL TO MODIFY THE EMISSION CONTROL SYSTEM, WHICH INCLUDES THE CARBURETORS OF ANY VEHICLE.

Assembly Diagram

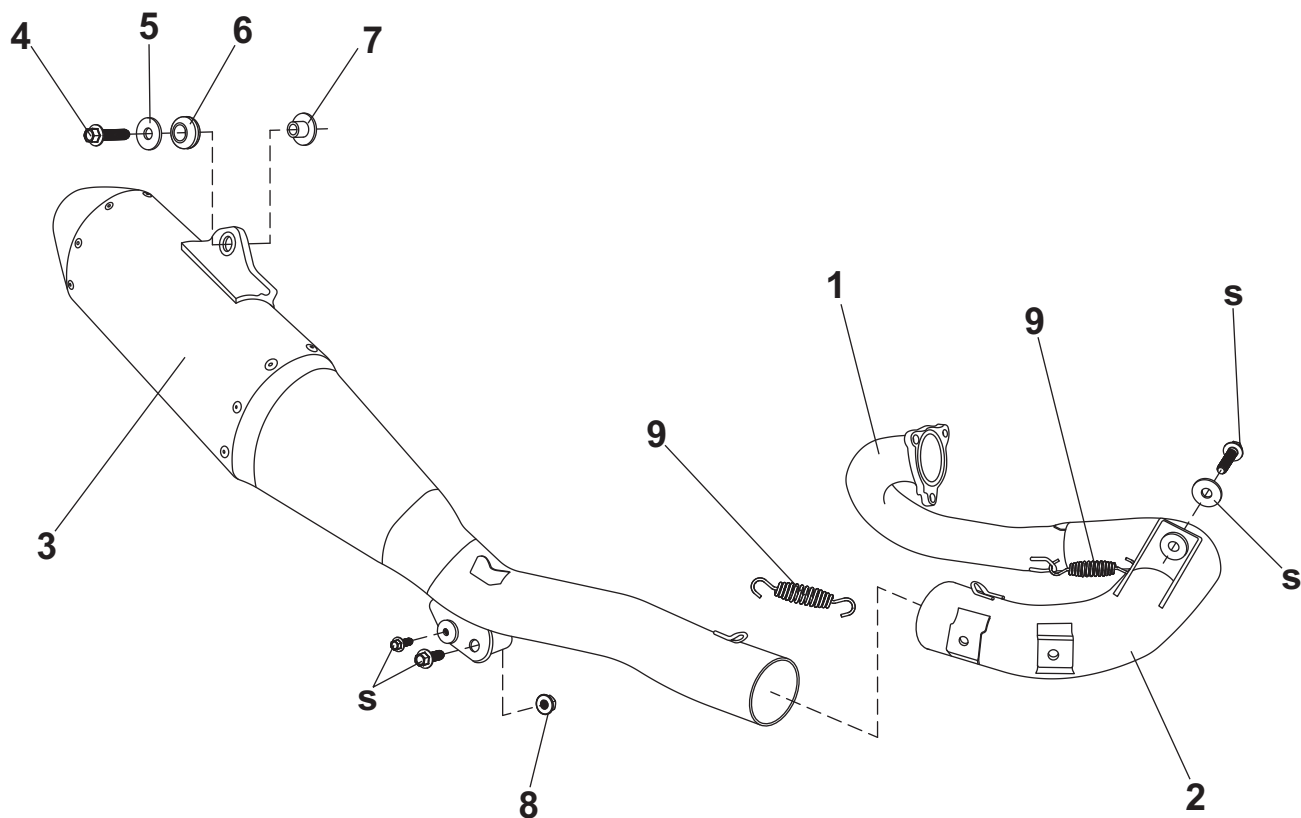

S = Stock

NO.	DESCRIPTION	QTY	PART #
1	Yoshimura Header	1	23481-101
2	Yoshimura Midpipe	1	23481-140-1
3	Yoshimura Muffler Assembly	1	234812D321-RMA
4	8mm x 35mm Flanged Hex Head Bolt	1	M8X35H
5	8mm Large Washer	1	8MMWASHERL
6	Rubber Grommet	1	Z1022
7	Aluminum Spacer	1	ALS-003
8	8mm Flange Nut	1	8MMNUT
9	Medium Exhaust Spring	2	RACE-SPS-1
**	8" x 10" Aluminum Heatshield Foil	1	ALFOILHS-8X10
**	Low Volume Sound Insert (1.50")	1	INS-19-K (Installed)
**	Low Volume Sound Insert (1.375")	1	INS-16-K
**	Offroad Endcap Plug	1	347PLUG
**	Spring Puller Tool	1	ST-200
**	Yoshimura Vinyl Sticker	1	17029
OPTIONAL REPLACEMENT PARTS			
Repack Kit		REPACK-RS4-PK26	

Removal

1. Remove the right side panel by removing the three side panel bolts.
2. Loosen the stock exhaust clamp at muffler to midpipe connection.
3. Remove the forward muffler chassis mount bolt.
4. While securely supporting the stock muffler assembly, remove the rear muffler mount bolt and carefully remove muffler from the stock midpipe.
5. Loosen the stock exhaust clamp at midpipe to header connection.
6. Remove midpipe support bracket bolt and carefully remove the stock midpipe from the header.
7. Remove the three header nuts and carefully remove the stock header.

Note: The stock exhaust port gasket will be re-used with the Yoshimura full-system. Inspect and replace if necessary.

Installation

1. Install (No. 6) Z1022, rubber grommet into Yoshimura muffler bracket.

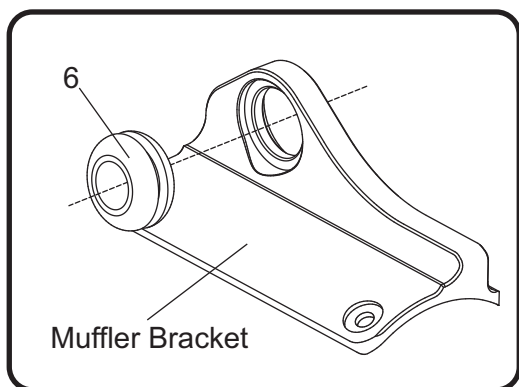

2. Install (No. 7) ALS-003, aluminum spacer into (No. 6) Z1022, rubber grommet as shown.

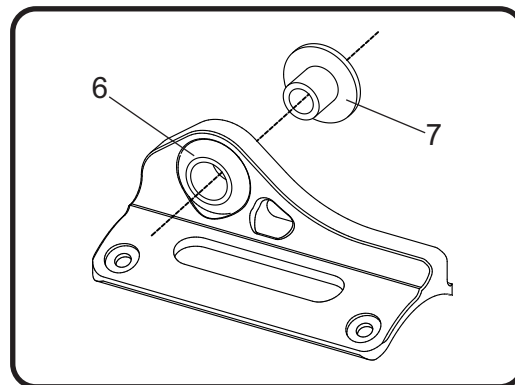

3. Install (No. 1) 23481-101, Yoshimura header using the stock header nuts. Do not torque at this time.
4. Carefully install (No. 2) 23481-140-1, Yoshimura midpipe by maneuvering between the frame and motor and slide the midpipe inlet over the header outlet. Secure midpipe to midpipe support bracket using the stock bolt and washer. Do not torque at this time.
5. Install (No. 3) 234812D321-RMA, Yoshimura muffler assembly by sliding over (No. 2) 23481-140-1, midpipe outlet.
6. Secure (No. 3) 234812D321-RMA, muffler assembly to muffler mount using (No. 4) M8X35H, bolt and (No. 5) 8MMWASHERL, washer supplied in the kit. Do not torque at this time.
7. Secure Yoshimura forward muffler chassis mount to chassis using the stock bolt and (No. 8) 8MMNUT, flange nut. See diagram for proper orientation. Do not torque at this time.
8. Torque (No. 4) M8X35H, rear muffler mount bolt to factory specification.
9. Torque the stock forward muffler chassis mount bolt to factory specification.
10. Install (No. 9) RACE-SPS-1, medium exhaust springs between muffler assembly tailpipe and (No. 2) 23481-140-1, midpipe.
11. Torque the stock midpipe support bracket bolt to factory specification.
12. Install (No. 9) RACE-SPS-1, medium exhaust spring between (No. 1) 23481-101, header and (No. 2) 23481-140-1, midpipe.
13. Torque header nuts to factory specification.

14. Install the stock header and midpipe heatshields onto Yoshimura header and midpipe.
15. Cut out the provided heatshield template along the solid line.
16. Using a pen or marker, trace the paper template onto provided adhesive foil.

Note: When tracing paper template onto foil sheet, be sure both templates fit.

17. Cut out heatshield foil.
18. Clean number plate thoroughly with soap and water where heatshield foil will be applied.
19. Remove adhesive backing from foil heatshield and apply onto the inside of the number plate.

Note: Be sure number plate is dry and clean prior to applying heatshield foil. Debris may hinder the foil from adhering to the surface.

20. Re-install right side panel.
21. Before starting motorcycle, check for proper clearance between new exhaust system and rear suspension (i.e. tire, swing arm, brakes, rear shock, and etc.) If any problem is found, please carefully follow through the installation steps again. If problem still persists, please call Yoshimura Tech Department at (800) 634-9166 / in CA (909) 628-4722.
22. It is recommended that the muffler and tailpipe be wiped down with rubbing alcohol to remove oil and fingerprints. This will help prevent tarnishing of the finish after the exhaust is heated up.

Note: After starting motorcycle, it is normal for new exhaust system and muffler to emit smoke until oil residue burns off.

