



YOSHIMURA

RESEARCH&DEVELOPMENT OF AMERICA, INC.

5420 DANIELS STREET STE A, CHINO CA., 91710 · (800) 634-9166 · (909) 628-4722 · FAX (909) 591-2198

www.yoshimura-rd.com

RACE SERIES

Qualified Manufacturer Declared "Modified Part"

2015~2016

Honda **CBR300R**
 CB300F

123002J220 (CF/CF)

123002J520 (SS/CF)

R-77 Stainless Steel Slip-On Exhaust

FOR CLOSED COURSE COMPETITION ONLY; NOT INTENDED FOR STREET USE

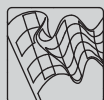

Race Series systems are:

- NOT CARB/EPA tail-pipe emissions compliant.
- NOT street legal.
- For "Closed Course Competition" use only.

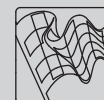

You must know how to remove and replace your stock exhaust in order to install this product otherwise have it installed by a professional mechanic. Keep all stock parts from your existing system as some components may be necessary to install your new Yoshimura exhaust depending on the application. Read through all instructions before beginning installation. Exhaust system can be extremely hot. Let motorcycle cool down before beginning installation. Always wear hand and eye protection and take precautionary measures to avoid injury.



NOTE: IN THE STATE OF CALIFORNIA, IT IS ILLEGAL TO MODIFY THE EMISSION CONTROL SYSTEM, WHICH INCLUDES THE CARBURETORS OF ANY VEHICLE.

Assembly Diagram

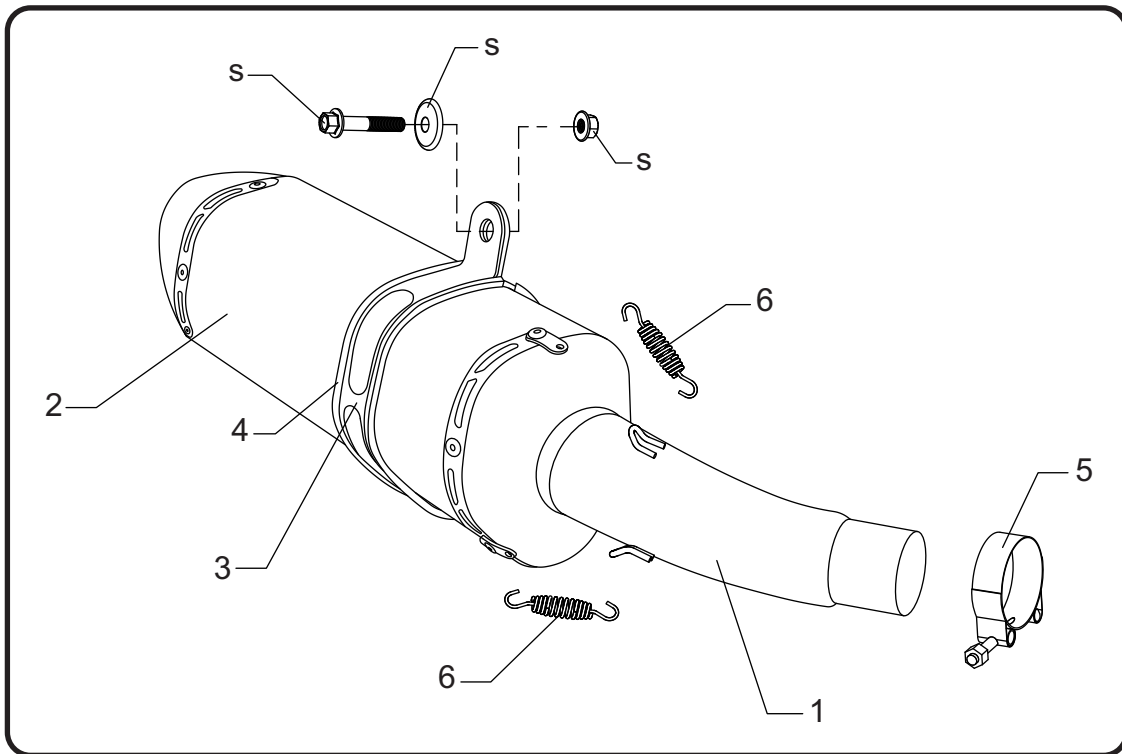

No.	Item	Description	Qty.
1	12300-435	Yoshimura Tailpipe	1
2	CRR77M14S SRR77M14S	Carbon Fiber Muffler Stainless Steel Muffler	1
3	YM7M-MPCA(X)	Muffler Clamp	1
4	HT SHLDR77	Muffler Clamp Heatshield	1
5	22055	Exhaust Clamp	1
6	RACE-SPS-1	Medium Exhaust Spring	2
**	S-RIVET	Securing Rivet	1
**	INS-04-K	Low Volume Insert	1
**	ST-200	Spring Puller Tool	1
**	17029	Sticker Kit Sheet	1

(X) Used for stainless steel muffler canister.
 ** Not shown in diagram.

Removal

1. Loosen the exhaust clamp on the inlet of the stock muffler assembly.
2. While supporting the stock muffler assembly, remove the muffler mount bolt securing the muffler assembly to subframe.
3. Carefully remove muffler assembly off of the header by sliding toward the rear of the bike.

Note: The stock exhaust gasket will not be used with the Yoshimura Slip-On system.

Installation

1. Slide (No. 5) 22055, exhaust clamp over (No. 1) 12300-435, Yoshimura tailpipe inlet as shown in the assembly diagram.

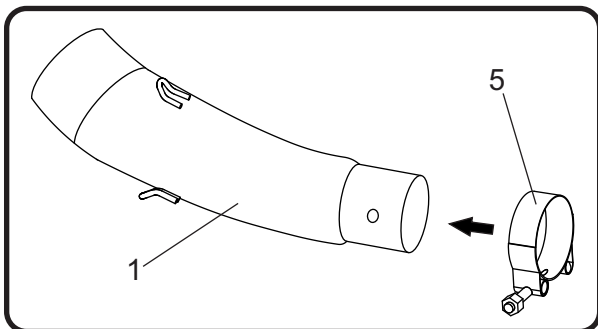

2. Install (No. 4) HT SHLDR77, muffler clamp heatshield onto (No. 3) YM7M-MPCA(X), muffler clamp.

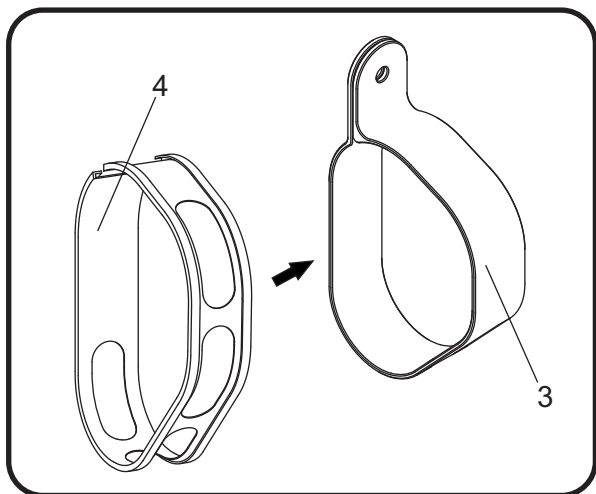

3. Slide (No. 3) YM7M-MPCA(X), muffler clamp over Yoshimura muffler.

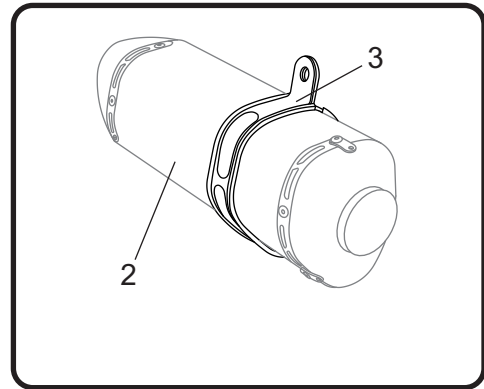

4. Slide (No. 1) 12300-435, Yoshimura tailpipe inlet over the stock header outlet.
5. Align (No. 3) YM7M-MPCA(X), muffler clamp to the inside of the stock muffler mount and secure using the stock bolt, washer, and nut. See diagram for proper orientation and order of hardware.

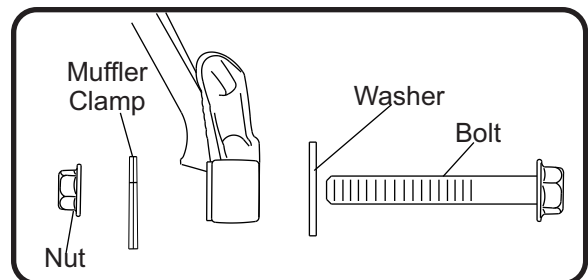

6. Standing at the back of the motorcycle, check for proper alignment of the muffler. Adjust if necessary.

Note: To adjust fitment, it may be necessary to rotate the tailpipe or the muffler independently until proper alignment of the muffler is achieved.

7. A securing rivet will be installed in the tailpipe to prevent the tailpipe from rotating while the motorcycle is in operation. Drill a 13/64" hole through the outlet of the stock header using the securing holes located near the Yoshimura tailpipe inlets as your guide.

Caution: Always wear eye protection when using any power tools.

8. Insert securing rivet into drilled hole and slide exhaust clamp over rivet and torque to 8.5 Nm (0.86 kg-m, 6 ft-lb).
9. Torque muffler mount bolt to 23 Nm (2.3 kg-m, 16.5 ft-lb).

10. Before starting vehicle, check for proper clearance between new exhaust system and rear suspension (i.e. tire, swingarm, brakes, rear shock, engine and etc.) If any problem is found, please carefully follow through the installation steps again. If problem still persists, please call Yoshimura Tech Department at (800) 634-9166 / in CA (909) 628-4722.

11. It is recommended that the muffler and tailpipe be wiped down with rubbing alcohol to remove oil and fingerprints. This will help prevent tarnishing of the finish after the exhaust is heated up.

Note: After starting vehicle, it is normal for new exhaust system and muffler to emit smoke until oil residue burns off.