



YOSHIMURA

RESEARCH&DEVELOPMENT OF AMERICA, INC.

5420 DANIELS STREET STE A, CHINO CA., 91786 · (800)634-9166 · (909)628-4722 · FACSIMILE (909)591-2198

www.yoshimura-rd.com

TRS TRI-OVAL PERFORMANCE EXHAUST SYSTEM

**SUZUKI
2003
SV1000/S**

113056(2,5,7)

ZYCLONE BOLT-ON SYSTEM

113046(2,5,7)

RACE ONLY BOLT-ON SYSTEM

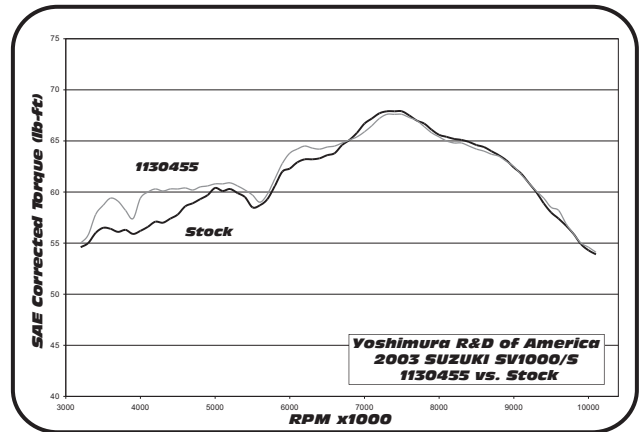
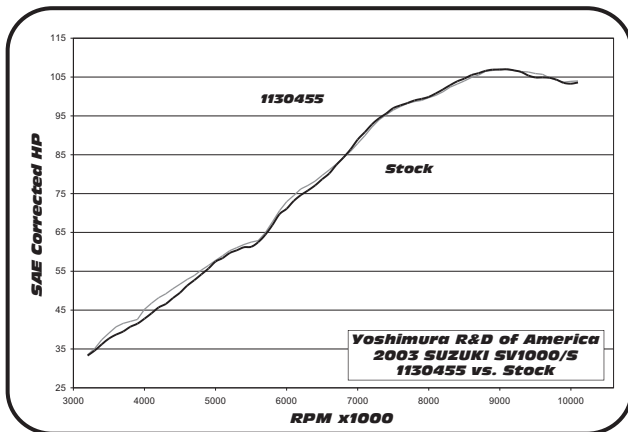

THIS PRODUCT IS DESIGNED FOR USE IN CLOSED COURSE RACING AND IS NOT INTENDED FOR HIGHWAY USE.



NOTE: IN THE STATE OF CALIFORNIA, IT IS ILLEGAL TO MODIFY THE EMISSION CONTROL SYSTEM, WHICH INCLUDES THE CARBURETORS OF ANY VEHICLE.

Caution: Exhaust system can be extremely hot. Let motorcycle cool down before beginning installation.

Note: Read through all instructions before beginning installation.

Tools Needed:

12mm socket
3/8" ratchet
12mm and 14mm wrenches
Torque wrench

Installation Steps:

- 1 Remove stock mufflers and muffler gaskets.
- 2 Install new muffler gaskets.
(Not supplied - Suzuki part no. 14181-02F00)
- 3 Install Yoshimura mufflers using supplied bolts.
Torque bolts to 2.3 kg-m (16.5 lb-ft).
- 4 Install muffler clamp heat insulator to inside of muffler clamps and slide clamps onto mufflers.
(note direction of clamps in Fig. 1&2)
- 5 Mount clamps to inside of stock muffler brackets using stock bolts, washers, and nuts. (see Fig. 1&2)
Torque bolt to 2.5 kg-m (18 lb-ft).
- 6 Check for proper clearance between new muffler and motorcycle. (i.e. swing-arm, passenger foot-peg, rear wheel, etc.) If any problem is found, please carefully follow through the installation steps again. If problem still persists, please call Yoshimura tech. Dept. at (800)634-9166 / in CA (909)628-4722

Note: After starting motorcycle, it is normal for new mufflers to smoke until oil residue burns off.

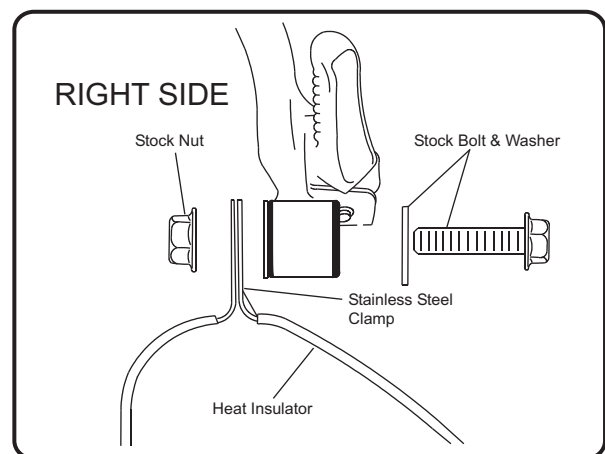

Right Side Fig. 1

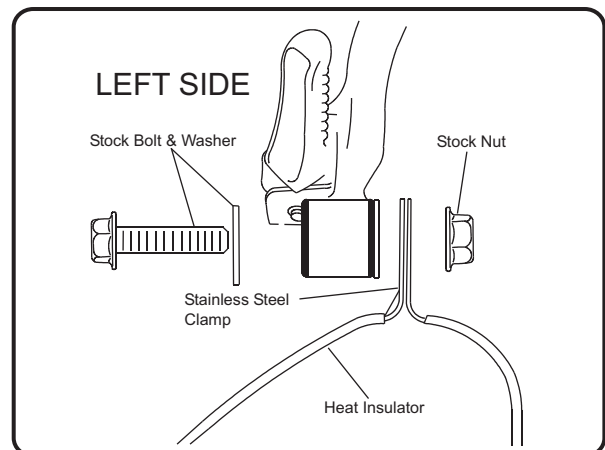

Left Side Fig. 2

#113046(2,5,7)/113056(2,5,7)

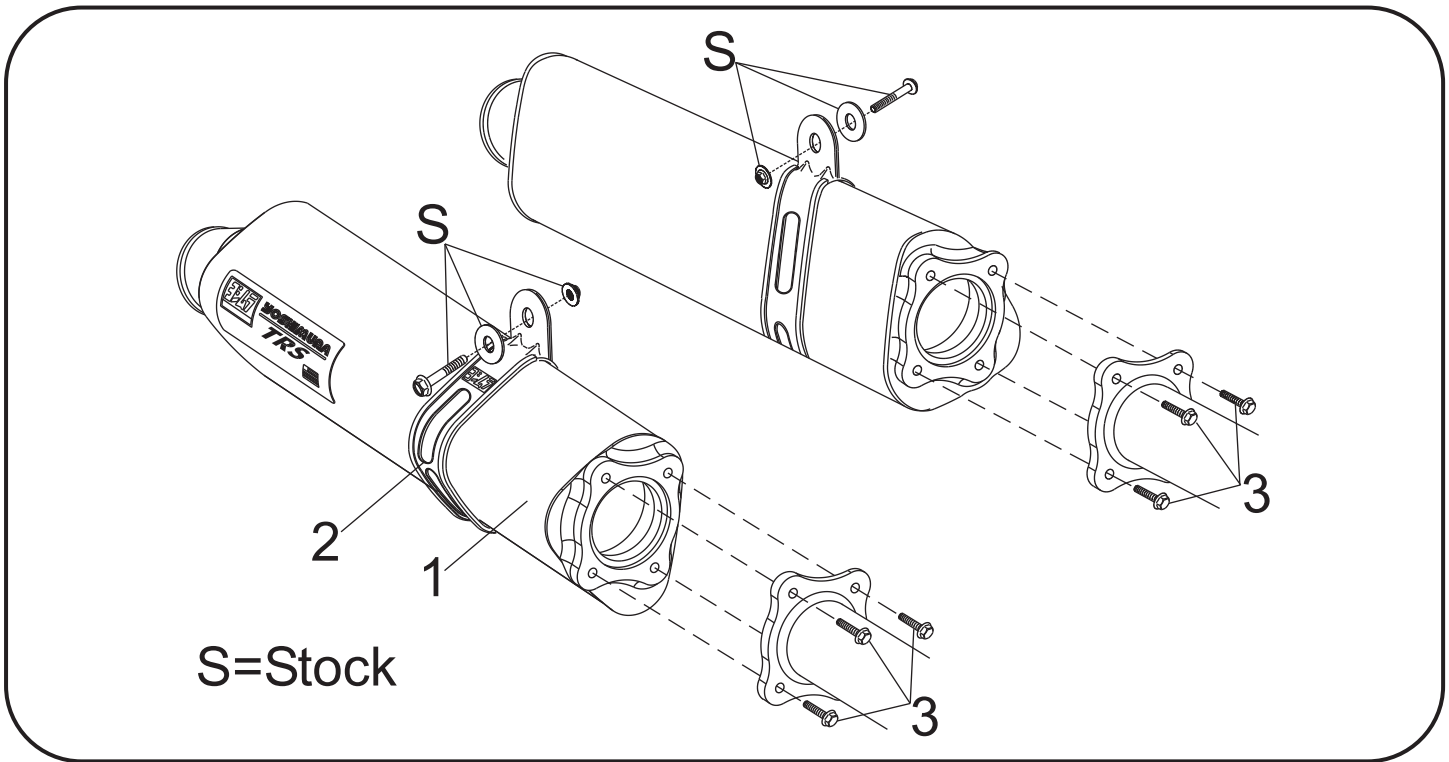

Parts Diagram

NO.	DESCRIPTION	QTY	PART #
1	TRS Tri- Oval Muffler Assembly	2	**
2	Stainless Steel Muffler Clamp Stainless Steel or Titanium Sleeve use Carbon Fiber Sleeve use		CTS082X CTS082
3	8mm x 20mm Flange Hex Bolt	8	M8X20H
**	Muffler Clamp Heat Insulator	2	HT SHLDTRS
**	TRS Insert Kit	2	TRS-INS-BK
**	Yoshimura Vinyl Sticker	1	17029

Nuts and Bolts Guide (Actual Size):

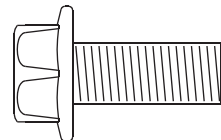

8mm x 20mm
Flange Hex Bolt