



# YOSHIMURA

RESEARCH&DEVELOPMENT OF AMERICA, INC.

5420 DANIELS STREET SUITE A, CHINO, CA 91710 · (800) 634-9166 · (909) 628-4722 · FAX (909) 591-2198

[www.yoshimura-rd.com](http://www.yoshimura-rd.com)

**SA-18-K**

**HONDA MONKEY RS-3 SPARK ARRESTER KIT**

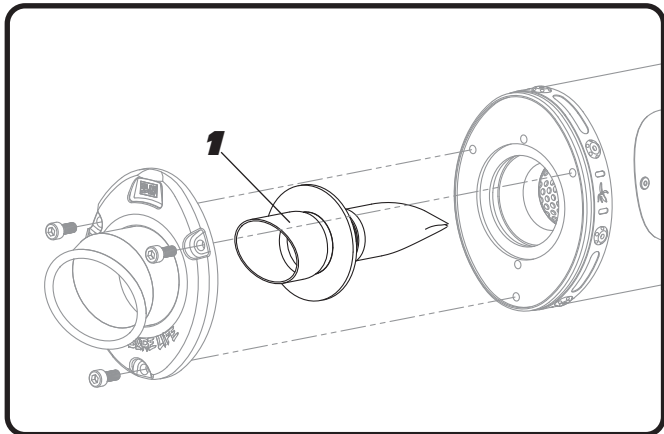

| NO. | DESCRIPTION               | QTY | PART #    |
|-----|---------------------------|-----|-----------|
| 1   | Monkey Insert             | 1   | 12130-INS |
| **  | USFS Spark Arrester Label | 1   | 17102     |

1. Remove the three endcap bolts
2. Remove endcap and install spark arrester.
3. Re-install endcap and endcap bolts.
4. Apply USFS certified spark arrester label on muffler where visible.

Note<sup>1</sup>: It is recommended that a low strength "Loc-tite" is used on the endcap bolts.

Note<sup>2</sup>: The spark arrester may reduce packing life due to excessive heat buildup from exhaust gas temperatures.

Note<sup>3</sup>: Re-packing is recommended at the same time spark arrester is being serviced.



# YOSHIMURA

RESEARCH&DEVELOPMENT OF AMERICA, INC.

5420 DANIELS STREET SUITE A, CHINO, CA 91710 · (800) 634-9166 · (909) 628-4722 · FAX (909) 591-2198

[www.yoshimura-rd.com](http://www.yoshimura-rd.com)

**SA-18-K**

**HONDA MONKEY RS-3 SPARK ARRESTER KIT**

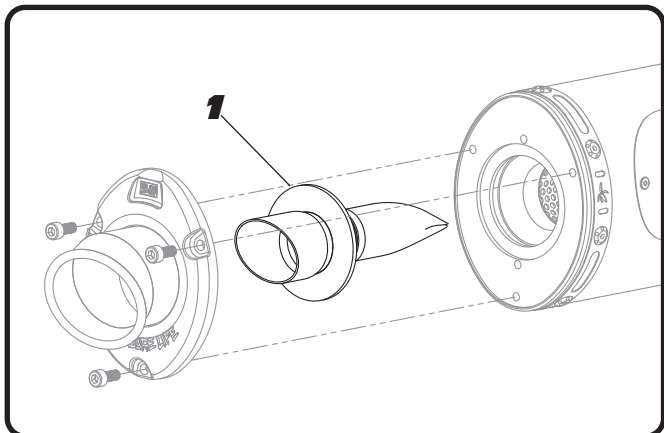

| NO. | DESCRIPTION               | QTY | PART #    |
|-----|---------------------------|-----|-----------|
| 1   | Monkey Insert             | 1   | 12130-INS |
| **  | USFS Spark Arrester Label | 1   | 17102     |

1. Remove the three endcap bolts
2. Remove endcap and install spark arrester.
3. Re-install endcap and endcap bolts.
4. Apply USFS certified spark arrester label on muffler where visible.

Note<sup>1</sup>: It is recommended that a low strength "Loc-tite" is used on the endcap bolts.

Note<sup>2</sup>: The spark arrester may reduce packing life due to excessive heat buildup from exhaust gas temperatures.

Note<sup>3</sup>: Re-packing is recommended at the same time spark arrester is being serviced.