

TR10

TAPPO SERBATOIO / FUEL TANK CAP
DUCATI STREETFIGHTER (09)
APRILIA RSV4 FACTORY (09)

 LightTech
Lightech s.r.l.

31025 - Santa Lucia di Piave (TV) Italy
Tel. 0438 / 453010 - Fax 0438 / 655919
<http://www.lightech.it> - Email: info@lightech.it

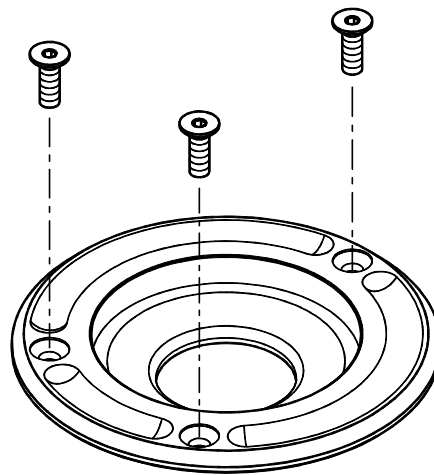
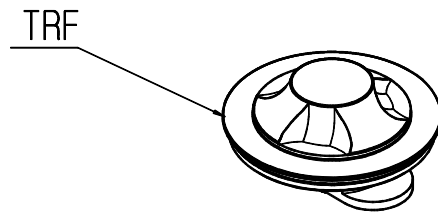

GUARNIZIONE
GASKET

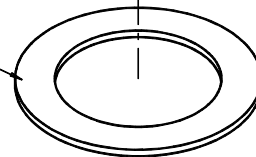

VITI UNI7380 M5x16 (4)
SCREWS UNI7380 M5x16 (4)

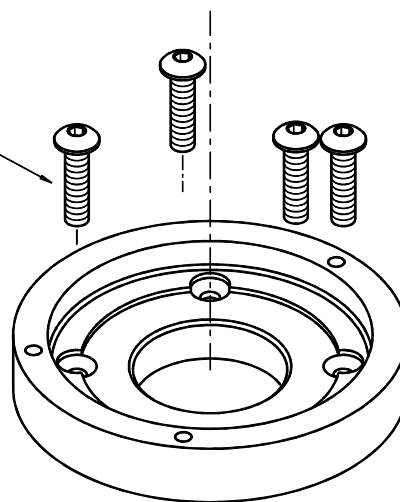

GUARNIZIONE ORIGINALE
ORIGINAL GASKET

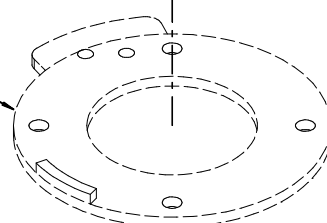

**TF10/TR10/TK10
TAPPO SERBATOIO / FUEL TANK CAP
DUCATI STREETFIGHTER 848 - 1100
APRILIA RSV 1000- RSV4 R - Factory - APRC- TUONO V4**



Eeguire il montaggio presso officine specializzate e da personale qualificato.
Lighttech srl non si assume alcuna responsabilità per eventuali danni a cose e/o persone causati da un montaggio errato.

To assembly it must be a specialized technician.
Lighttech s.r.l. will not be responsible to any damages caused by a wrong assembly.

Utensili necessari :

Chiave a Brugola da 3 mm
Chiave a Brugola da 4 mm

Nota :

- Utensili non compresi nella fornitura
- Gli utensili devono essere in buona condizione d'uso

Utensili necessari :

3 mm Allen key
4 mm Allen key

Nota :

- Tools are not include in delivery
- The tools must be in good condition of use

Dimensione Viti Screw Size	Coppia di chiusura Tightening torque
M5	3,00 Nm

**Rimuovere il tappo originale
Remove the original cap**



Fig. 1

**Vista con tappo rimosso
Tank without original cap**



Fig. 2

Orientare la flangia
Orientate the flange

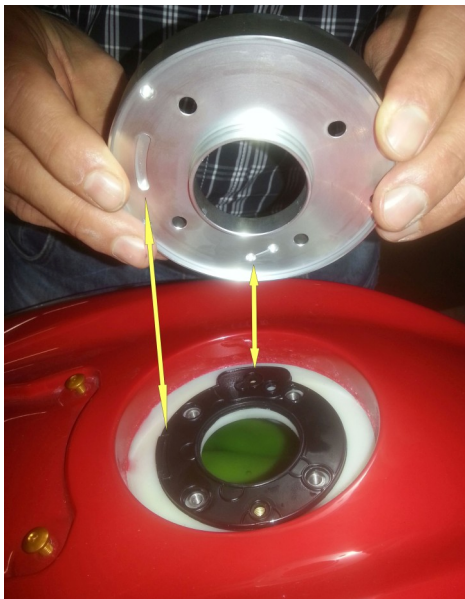

Fig. 3

Fissare la flangia
Fix the flange



Fig. 4

Posizionare la guarnizione
Position the gasket



Fig. 5

Fissare il tappo
Tightening the cap screws



Fig. 6