

Kit Contents

Description	Part No	Pcs
Shock absorber	YA426/427	1
Tool pre-load adj. cruiser	03199-03	1
Seal ball joint	00534-02	8
Bolt	00439-18	1
Spacer	01218-36	2
Spacer	01218-54	6
Sticker Öhlins	00192-01	2
Sticker memo notes	01180-01	1
Owner's manual	07241-02	1

👁 Note!

Please note that this image is a general representation of the product and may differ slightly from your product.

👁 Note!

Please note that during storage and transportation, especially at high ambient temperature, some of the oil and grease used for assembling may leak and stain the packaging. This is in no way detrimental to the product, wipe off the excessive oil/grease with a cloth.

👁 Note!

Before installing this product, check the contents of the kit. If anything is missing, please contact an Öhlins dealer.

⚠ Warning!

Before installing this product, read the Öhlins Owner's Manual. The shock absorber/front fork/steering damper is an important part of your vehicle and will affect the stability.

Shock absorber for Yamaha V-Max

YA 426/ 427

Mounting Instructions



MOUNTING INSTRUCTIONS

⚠ Warning!

It is advisable to have an Öhlins dealer install the shock absorber/front fork/steering damper.

⚠ Warning!

If working on a raised vehicle, ensure it is securely supported so that it will not tip.

👁 Note!

Before mounting this product clean the vehicle thoroughly.

👁 Note!

When working on this product, always see the Vehicle Service Manual for vehicle specific procedures and important data.

1

Put the motorcycle on a workstand so that the rear wheel barely touches the ground.

2

Loosen and remove the original shock absorbers. Consult your motorcycle workshop manual for advice.

3

Remove the original bracket bolt from the brake caliper and use the allen bolt (00439-18) provided in this kit.

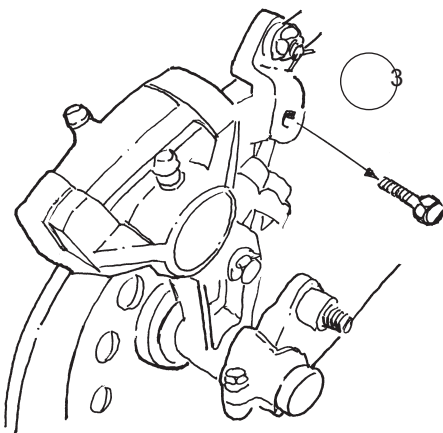

4

Install the Öhlins shock absorbers in the same position as the original units. The cylinder heads upwards and the piggy back reservoirs backwards. Install the spacers provided in this kit. See figures.

👁 Caution!

There is a left hand and a right hand shock absorber. The reservoir mount is angled slightly outwards to the left and to the right side. If the shock absorbers are installed with the reservoirs angled towards the wheel they can be damaged.

👁 Note!

Lower the vehicle so that the suspension is slightly compressed before tightening the screws.

👁 Caution!

Ensure that all screws are tightened to the correct torque and that nothing fouls or restricts movement of the shock absorber/front fork/steering damper when the suspension is fully compressed or extended.

MOUNTING INSTRUCTIONS

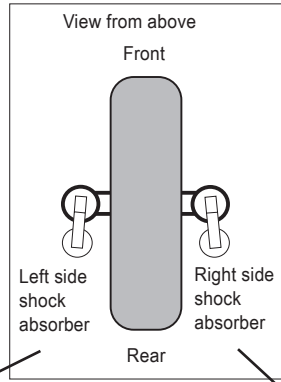
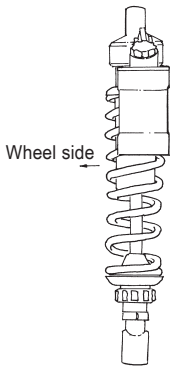

4

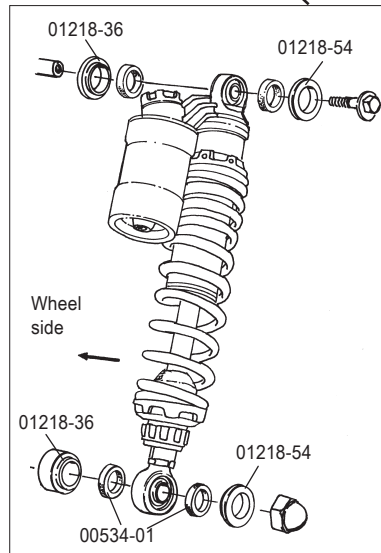
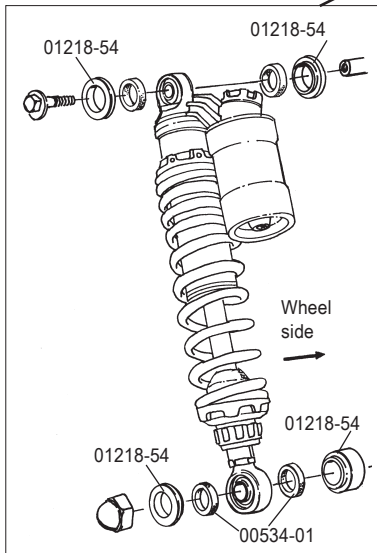

ADJUSTMENTS

⚠ Warning!

Before riding, always make sure that the basic settings made by Öhlins are according to recommended Set-up Data. Read about adjustments and setting up in the Öhlins Owner's Manual before you make any adjustments. Contact an Öhlins dealer if you have any questions about setting up.

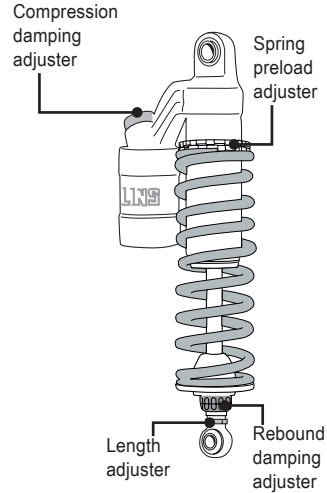

SET-UP DATA

Length	325 ⁺¹⁰ / ₀	mm
Stroke	92	mm
Rebound	12	clicks
Compression	2	clicks
Spring preload	15	mm

👁 Öhlins products are subject to continuous improvement and development, therefore, although these instructions include the most up-to-date information available at the time of printing, minor updates may occur.

To find the latest information contact an Öhlins distributor. Please contact Öhlins if you have any questions regarding the contents in this document.

Part no. MI_YA426_427_4
Issued 2014-03-10

© Öhlins Racing AB. All rights reserved. Any reprinting or unauthorized use without the written permission of Öhlins Racing AB is prohibited.

Öhlins Racing AB
Box 722
S-194 27 Upplands Väsby, Sweden
Phone +46 8 590 025 00
fax +46 8 590 025 80



www.ohlins.com