



FITTING INSTRUCTIONS FOR AR0001SI ADVENTURE LUGGAGE RACK KTM 790 ADVENTURE 2019



Picture A



Picture B

THIS KIT CONTAINS THE ITEMS PICTURED AND LABELLED OVER PAGE.

SOME PARTS MAY BE SHOWN FOR CLARITY OF INSTRUCTIONS ONLY.

DO NOT PROCEED UNTIL YOU ARE SURE ALL PARTS ARE PRESENT.

PLEASE READ ALL INSTRUCTIONS BEFORE PROCEEDING.

PLEASE NOTE THAT THE WAY THE KIT IS PACKED DOES NOT NECESSARILY REPRESENT THE WAY OF MOUNTING TO THE BIKE.

IN THE EVENT OF RUBBER WASHERS BEING USED TO HOLD COMPONENTS ONTO BOLTS,
THESE RUBBER WASHERS CAN BE THROWN AWAY.

DIGITAL COPIES OF THESE INSTRUCTIONS ARE AVAILABLE FROM:

WWW.RG-RACING.COM

R&G Racing

Unit 1, Shelleys Lane, East Worldham, Alton, Hampshire GU34 3AQ.

Tel: +44 (0)1420 89007 Fax +44 (0)1420 87301 www.rg-racing.com Email: info@rg-racing.com



<u>TOOLS REQUIRED</u>	<u>GENERAL TORQUE SETTINGS</u>
<ul style="list-style-type: none"> • T45 Torx Tool • 5mm A/F Allen Tool • Torque Wrench 	<p>M4 BOLT = 8Nm</p> <p>M5 BOLT = 12Nm</p> <p>M6 BOLT = 15Nm</p> <p>M8 BOLT = 20Nm</p> <p>M10 BOLT = 40Nm</p> <p>M12 BOLT = 40Nm</p>

LEGEND

ITEM No.	DESCRIPTION	QTY
ITEM 1	SMW0151 ADVENTURE RACK—BRUSHED	1
ITEM 2	S1196 SHORT ANGLED TOP-HAT SPACER	2
ITEM 3	S1197 TALL ANGLED TOP-HAT SPACER	2
ITEM 4	M8 x 1.25 x 70.00mm LONG COUNTERSINK BOLT	2
ITEM 5	M8 x 1.25 x 60.00 LONG COUNTERSINK BOLT	2

EXPLODED ASSEMBLY DIAGRAM

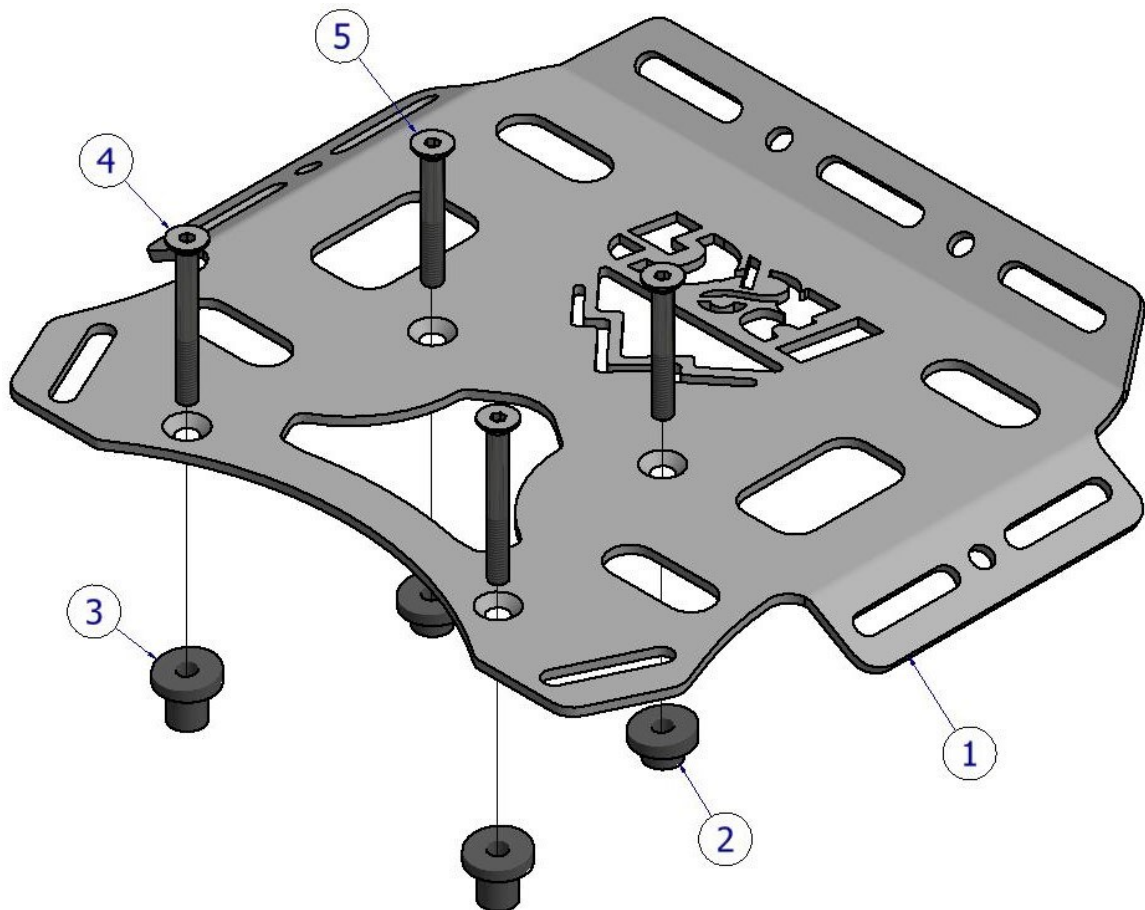

R&G Racing

Unit 1, Shelleys Lane, East Worldham, Alton, Hampshire GU34 3AQ.

Tel: +44 (0)1420 89007 Fax +44 (0)1420 87301 www.rg-racing.com Email: info@rg-racing.com

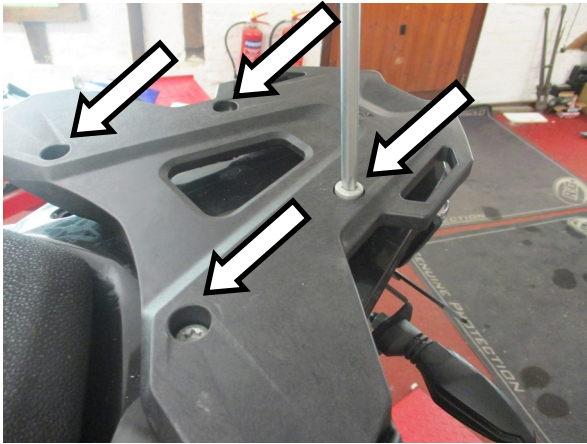

Picture 1

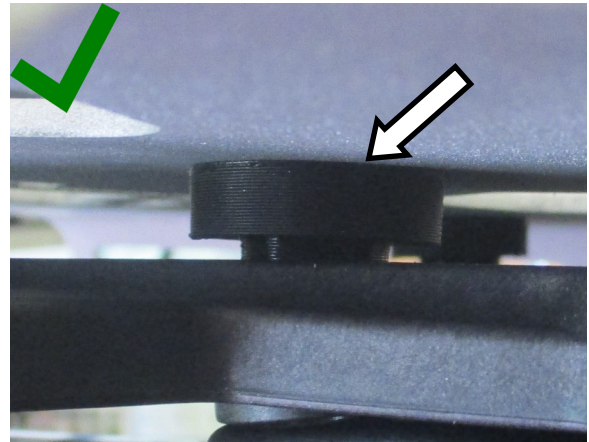

Picture 2

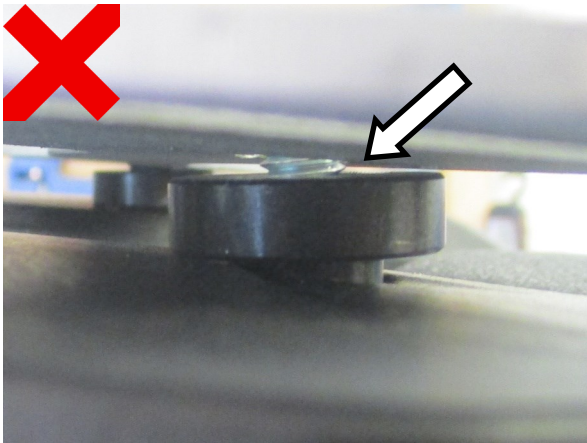

Picture 3



Picture 4

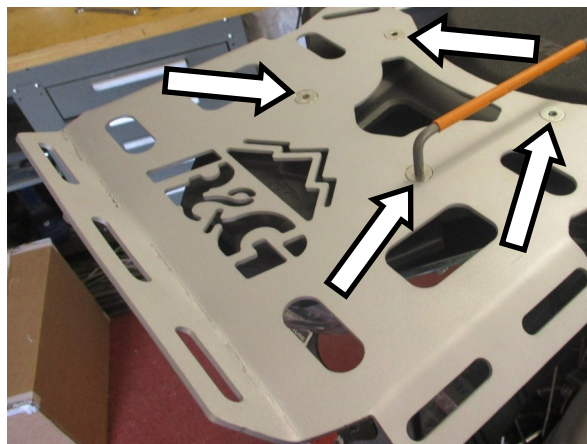

Picture 5



Picture 6

R&G Racing

Unit 1, Shelleys Lane, East Worldham, Alton, Hampshire GU34 3AQ.

Tel: +44 (0)1420 89007 Fax +44 (0)1420 87301 www.rg-racing.com Email: info@rg-racing.com



FITTING INSTRUCTIONS

- Remove the 4x T45 bolts shown in picture 1, ensuring that the OEM rack and both grab rails are supported to prevent them from dropping, and keep them in place.
- Referring to the diagram on page 2 as well as pictures 2 & 3, place the 2 longer top-hat spacers (item 3) in the 2 frontmost (closest to seat) mounting wells of the OEM rack, then place the 2 shorter top-hat spacers (item 2) in the rearmost (closest to end of bike) wells.
- Referring to pictures 2 and 3, rotate the spacers so that the R&G Adventure Rack (item 1) sits flat on top of all 4 spacers and parallel to the OEM rack surface, as shown in picture 4.
- Line up the countersunk R&G rack mounting holes with those of the spacers, then insert the 2 M8 x 70mm countersink bolts (item 4) into the frontmost holes as shown in the diagram on page 2. Secure using a 5mm Allen key as shown in picture 5, but do not fully tighten.
- Insert the 2 M8 x 60mm countersink bolts (item 5) into the rearmost holes and secure with a 5mm Allen key, then fully tighten all bolts and torque to 20Nm.
- **Please note - KTM recommend not to exceed a 5kg load capacity on the OEM rack.**

ISSUE 1 - 23/08/2019 (FB)

CONSUMER NOTICE

The catalogue description and any exhibition of samples are only broad indications of the Products and R&G may make design changes which do not diminish their performance or visual appeal and supplying them in such state shall conform to the order. The Buyer acknowledges no representation or warranty (other than as to title) has been given or will apply to the Products other than those in R&G's order or confirmation and the Buyer confirms it has chosen the Products as being of merchantable quality and suitable for its particular purposes. Where R&G fits the Products or undertakes other services it shall exercise reasonable skill and care and rectify any fault free of charge unless the workmanship has been disturbed. The Buyer is responsible for ensuring that the warranty on the motorcycle is not affected by the fitting of the Products. On return of any defective Products R&G shall at its option either supply a replacement or refund the purchase money but shall not be liable if the Products have been modified or used or maintained otherwise than in accordance with R&G's or manufacturer's instructions and good engineering practice or if the defect arises from accident or neglect. Other than identified above and subject to R&G not limiting its liability for causing death and personal injury, it shall not be liable for indirect or consequential loss and otherwise its liability shall be limited to the amounts paid by the Buyer for the Products or the fitting or service concerned. These terms do not affect the Buyer's statutory rights.

R&G RETURNS POLICY (NON-FAULTY GOODS)

Returns must be pre-authorized (if not pre-authorized the return will be rejected). Goods may only be returned direct to us if they were purchased direct from us (customer must prove if necessary). Otherwise to be returned to original vendor. Goods must be in re-sellable condition, in the opinion of R&G. All returns are subject to a 25% restocking and handling fee (25% of the gross value exc. P&P – at the prevailing price at time of purchase). The customer must pay any and all carriage charges. No returns of discontinued products, unless within 14 days of purchase. This policy does not affect your statutory rights and does not refer to faulty goods.

R&G Racing

Unit 1, Shelleys Lane, East Worldham, Alton, Hampshire GU34 3AQ.

Tel: +44 (0)1420 89007 Fax +44 (0)1420 87301 www.rg-racing.com Email: info@rg-racing.com



NOTICE DE MONTAGE AR0001SI PORTE BAGAGE AVENTURE KTM 790 ADVENTURE 2019



Photo A



Photo B

LE KIT CONTIENT LES ARTICLES EN PHOTO ET ETIQUETTES SUR LA PAGE

LES PARTIES PRÉSENTÉES PEUVENT ÊTRE UNIQUEMENT REPRESENTATIVES POUR LA CLARTE DES INSTRUCTIONS
NE PAS PROCÉDER AU MONTAGE AVANT DE VOUS ÊTRE ASSURÉ QUE TOUTES LES PIÈCES SOIENT PRÉSENTES.

SVP, LIRE L'ENSEMBLE DE LA NOTICE AVANT DE PROCÉDER AU MONTAGE.

LA FAÇON DONT LE KIT EST EMBALLÉ NE CORRESPOND PAS FORCÉMENT À LA FAÇON DE MONTER LES
PIÈCES SUR LA MOTO .

NOTEZ QUE SI LES KITS SONT EMBALLÉS AVEC DES RONDELLES EN CAOUTCHOUC SERVANT À TENIR
LES COMPOSANTS, CES RONDELLES DOIVENT ÊTRE JETÉES.

NOTICE DISPONIBLE AU TÉLÉCHARGEMENT SUR : WWW.RG-RACING.COM

R&G Racing

Unit 1, Shelleys Lane, East Worldham, Alton, Hampshire GU34 3AQ.

Tel: +44 (0)1420 89007 Fax +44 (0)1420 87301 www.rg-racing.com Email: info@rg-racing.com



<u>OUTILS REQUIS</u>	<u>VALEURS DE SERRAGE</u>
<ul style="list-style-type: none"> • Cle Torx T45 • Cle Allen 5mm • Cle dynamométrique 	M4 BOULON = 8Nm M5 BOULON = 12Nm M6 BOULON = 15Nm M8 BOULON = 20Nm M10 BOULON = 40Nm M12 BOULON = 40Nm

LEGENDE

ARTICLE No.	DESCRIPTION	QTE
ARTICLE 1	SMW0151 PORTE BAGAGE	1
ARTICLE 2	S1196 ENTRETOISE	2
ARTICLE 3	S1197 ENTRETOISE	2
ARTICLE 4	M8 x 1.25 x 70.00mm BOULON	2
ARTICLE 5	M8 x 1.25 x 60.00 BOULON	2

NOTICE DE MONTAGE

- Retirez les 4 boulons T45 illustrés sur la photo 1, en veillant à ce que le rack d'origine et les deux barres d'appui soient bien en place, afin qu'ils ne tombent pas, et maintenez-les en place.
- En vous référant au schéma de la page 2 ainsi qu'aux photos 2 et 3, placez les 2 entretoises les plus longues (article 3) dans les 2 puits de montage les plus à l'avant (les plus proches du siège) du rack d'origine, puis placez les 2 entretoises les plus courtes (article 2) dans les puits les plus reculés (plus proches de l'extrémité de la moto).
- En vous référant aux photos 2 et 3, faites pivoter les entretoises de manière à ce que le porte bagage R&G (article 1) repose à plat sur les quatre entretoises et parallèlement à la surface du rack d'origine, comme indiqué sur la photo 4.
- Alignez les trous de montage fraisés du rack R & G avec ceux des entretoises, puis insérez les 2 boulons à tête fraisée M8 x 70mm (article 4) dans les trous les plus à l'avant, comme indiqué sur le schéma de la page 2. Fixez à l'aide d'une clé Allen de 5 mm, comme indiqué sur la photo. 5, mais ne pas serrer complètement.
- Insérer les 2 boulons M8 x 60mm (article 5) dans les trous les plus reculés et fixer avec une clé Allen de 5mm, puis serrer à fond toutes les vis à 20Nm.
- **Remarque: KTM recommande de ne pas dépasser une capacité de charge de 5 kg sur le rack OEM.**

ISSUE 1 - 23/08/2019 (FB)

R&G Racing

Unit 1, Shelleys Lane, East Worldham, Alton, Hampshire GU34 3AQ.

Tel: +44 (0)1420 89007 Fax +44 (0)1420 87301 www.rg-racing.com Email: info@rg-racing.com



MONTAGEANLEITUNG FÜR AR0001SI ADVENTURE GEPÄCKTRÄGER KTM 790 ADVENTURE 2019



Abbildung A



Abbildung B

ALLE KIT-TEILE SIND UNTEN ABGEBILDET UND GEKENNZEICHNET.

DIE ABGEBILDETEN TEILE DIENEN LEDIGLICH ZUR ERKLÄRUNG.

ÜBERPRÜFEN SIE ZUERST, DASS ALLE TEILE VORHANDEN SIND.

LESEN SIE DIE MONTAGEANLEITUNG KOMPLETT DURCH, BEVOR SIE ANFANGEN.

**WENN SIE BEI DER MONTAGE DIESES PRODUKTES UNSICHER SIND , BITTE EINEN
UNSERER HÄNDLER KONTAKTIEREN ODER DAS KIT VON EINEM QUALIFIZIERTEN
ZWEIRAD-MECHANIKER MONTIEREN LASSEN.**

DIE VERPACKUNG DER TEILE STELLT NICHT DIE REIHENFOLGE DER MONTAGE DAR.

HINWEIS FÜR KITS MIT PLASTIKUNTERLEGSSCHEIBEN AN DEN SCHRAUBEN –
DIESE PLASTIK-UNTERLEGSSCHEIBEN WERDEN NICHT FÜR DEN EINBAU BENÖTIGT!

**EINE DIGITALE VERSION DIESER MONTAGEANLEITUNG KANN AUF
FOLGENDER SEITE HERUNTERGELADEN WERDEN:**

WWW.RG-RACING.COM

R&G Racing

Unit 1, Shelleys Lane, East Worldham, Alton, Hampshire GU34 3AQ.

Tel: +44 (0)1420 89007 Fax +44 (0)1420 87301 www.rg-racing.com Email: info@rg-racing.com

<u>SIE BRAUCHEN FOLGENDES WERKZEUG</u>	<u>ALLGEM. ANZUGSDREHMOMENT</u>
<ul style="list-style-type: none"> • T45 Torx-Schlüssel • 5mm A/F Inbusschlüssel • Drehmomentschlüssel 	<p>M4 SCHRAUBE = 8Nm</p> <p>M5 SCHRAUBE = 12Nm</p> <p>M6 SCHRAUBE = 15Nm</p> <p>M8 SCHRAUBE = 20Nm</p> <p>M10 SCHRAUBE = 40Nm</p> <p>M12 SCHRAUBE = 40Nm</p>

LIEFERUMFANG

ARTIKEL NR.	BESCHREIBUNG	MENGE
ARTIKEL 1	SMW0151 ADVENTURE GEPÄCKTRÄGER—GEBÜRTSTET	1
ARTIKEL 2	S1196 DISTANZBUCHSE	2
ARTIKEL 3	S1197 DISTANZBUCHSE	2
ARTIKEL 4	M8 x 1,25 x 70 mm SENKSCHRAUBE	2
ARTIKEL 5	M8 x 1,25 x 60 mm SENKSCHRAUBE	2

EXPLOSIONSZEICHNUNG ZUSAMMENBAU

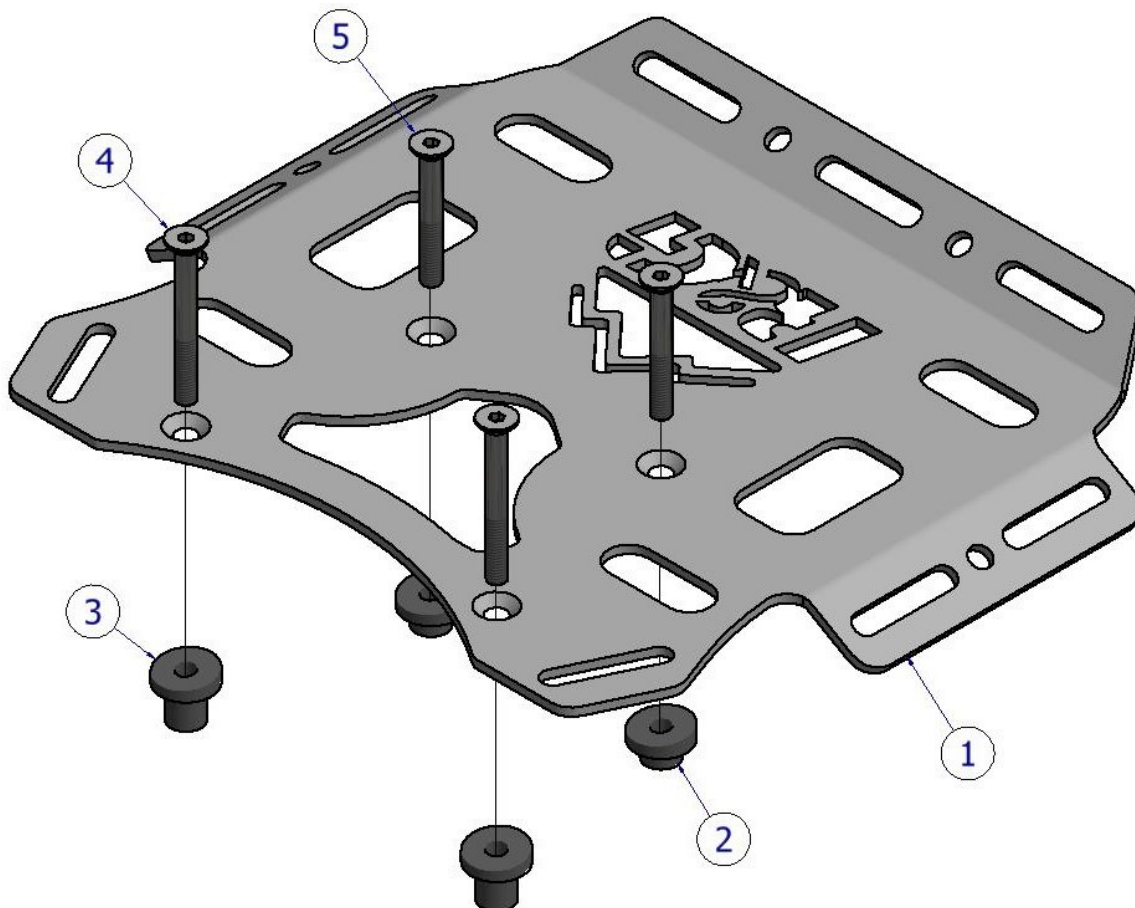

R&G Racing

Unit 1, Shelleys Lane, East Worldham, Alton, Hampshire GU34 3AQ.

Tel: +44 (0)1420 89007 Fax +44 (0)1420 87301 www.rg-racing.com Email: info@rg-racing.com



MONTAGEANLEITUNG

- Entfernen Sie die 4x T45 Schrauben, die in Abbildung 1 abgebildet sind. Achten Sie dabei darauf, dass Sie den original Gepäckträger und die zwei Haltegriffe gestützt sind, um zu verhindern, dass Sie runter fallen, und halten Sie sie in Position.
- Wie in der Zeichnung auf Seite 2 sowie in den Abbildungen 2 & 3 abgebildet, die zwei längeren Distanzbuchsen (Artikel 3) in den 2 vordersten (in der Nähe des Sitzes) Montagevertiefungen des original Gepäckträgers montieren, danach die 2 kürzeren Distanzbuchsen (Artikel 2) in den hintersten Vertiefungen (in der Nähe des Hecks) .
- Wie in den Abbildungen 2 und 3 abgebildet, die Distanzhalter drehen, sodass der R&G Adventure Gepäckträger (Artikel 1) flach auf allen 4 Distanzhalter und parallel zur Oberfläche des original Gepäckträgers sitzt wie in Abbildung 4 abgebildet.
- Die gesenkten Montageöffnungen des R&G Gepäckträgers mit den Montageöffnungen in den Distanzhaltern ausrichten und die zwei 2 M8 x 70mm Senkschrauben (Artikel 4) in die vorderen Öffnungen einsetzen wie in der Zeichnung auf Seite 2 abgebildet. Mit einem 5mm Inbusschlüssel sichern wie in Abbildung 5 abgebildet, aber nicht komplett festziehen.
- Die zwei M8 x 60mm Senkschrauben (Artikel 5) in die hintersten Öffnungen eindrehen und mit einem 5mm Inbusschlüssel befestigen. Danach alle Schrauben festziehen und mit 20Nm befestigen.
- **Bitte beachten Sie - KTM empfiehlt, eine Tragfähigkeit von 5 kg auf dem Rack nicht zu überschreiten.**

AUSGABE 1 - 23/08/2019 (FB)

R&G Racing

Unit 1, Shelleys Lane, East Worldham, Alton, Hampshire GU34 3AQ.

Tel: +44 (0)1420 89007 Fax +44 (0)1420 87301 www.rg-racing.com Email: info@rg-racing.com