



**FITTING INSTRUCTIONS FOR LGFK0020C LEVER-GUARD FITTING KIT
TO FIT KAWASAKI H2 SX 2018-**



PLEASE ENSURE THAT THIS PRODUCT WILL FIT BEFORE ANY REMOVAL OR MODIFICATIONS OF PARTS ARE MADE TO YOUR MOTORCYCLE

**THIS KIT CONTAINS THE ITEMS PICTURED AND LABELLED BELOW.
DO NOT PROCEED UNTIL YOU ARE SURE ALL PARTS ARE PRESENT.**

Please note that the way the kit is packed does not necessarily represent the way of mounting to the bike

THE PARTS SHOWN MAY BE REPRESENTATIVE ONLY (FOR CLARITY OF INSTRUCTIONS ONLY)

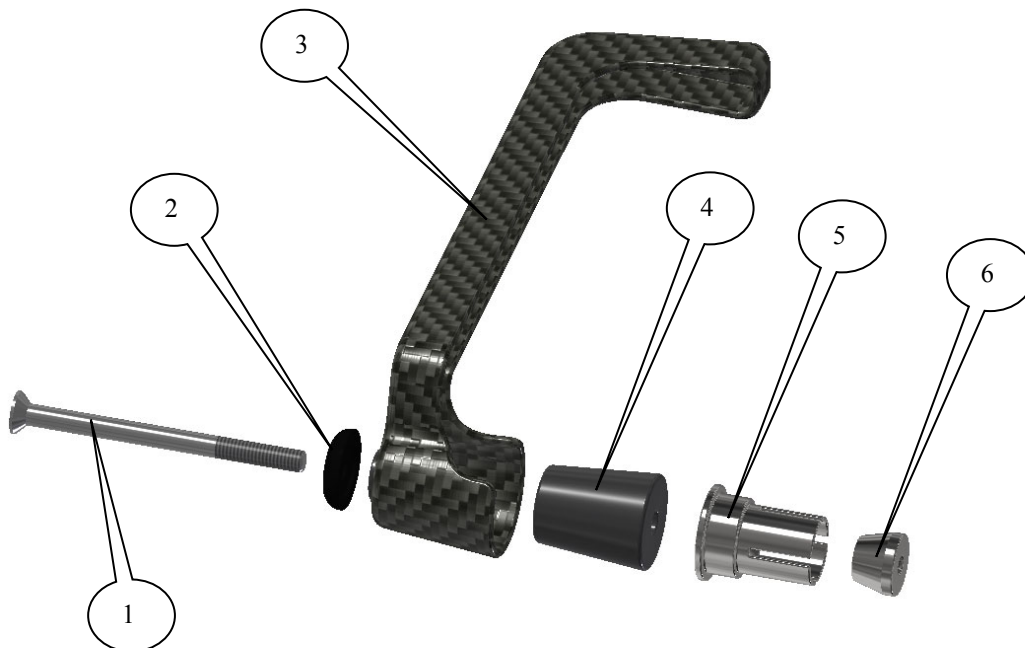



LEGEND

- ITEM 1 = M6 x 80mm LONG COUNTERSUNK BOLT (x1).
- ITEM 2 = CLAMP SPACER (S0928) (x1).
- ITEM 3 = CARBON LEVER GUARD (NOT INCLUDED IN FITTING KIT) (LG0001) (x1).
- ITEM 4 = CONE SPACER (S0781) (x1).
- ITEM 5 = EXPANDING SPACER (S0569) (x1).
- ITEM 6 = TAPERED NUT (H0032) (x1).

TOOLS REQUIRED

- Set of Allen keys to include 4mm A/F.
- Whatever tools required to remove original bar-end if applicable.

FITTING INSTRUCTIONS

- To fit the Lever Guard (item 2) remove the original bar end.
- Place the counter-sunk bolt (Item 1) through the clamp spacer (Item 2) and then through the Lever Guard (Item 3) so the flat face of the spacer sits against the front face of the lever guard as shown in the exploded diagram.
- Insert the cone spacer (Item 4) through the protruded end of the bolt so the spacer sits inside the lever guard.
- Insert the Expander (Item 5) through the protruded end of the bolt, follow by the tapered nut (Item 6). Ensure that the tapered nut sits in the expander. Do not fully tighten the nut into the expander at this stage.
- Offer the whole assembly into the handle-bar until the expanding spacer (Item 5) sits against the face of the handle-bar tube.
- Position the lever guard so when the handle bar is at full lock in both directions it does not make any contact with any other part of the motorcycle.
- Fully tighten the bolt and check operation.

IMPORTANT:- WHEN FITTING THIS PRODUCT IT IS YOUR RESPONSIBILITY TO ENSURE THAT THE PRODUCT IN NO WAY IMPEDES THE OPERATION OF THE MOTORCYCLE AND IS CHECKED REGULARLY FOR TIGHTNESS AND OPERATION.

FAILURE TO CHECK THE ABOVE COULD RESULT IN SERIOUS INJURY OR DAMAGE.

Digital copies of these instructions are available to download from www.rg-racing.com

ISSUE 1 14/11/2018 (NSY)

CONSUMER NOTICE

The catalogue description and any exhibition of samples are only broad indications of the Products and R&G may make design changes which do not diminish their performance or visual appeal and supplying them in such state shall conform to the order. The Buyer acknowledges no representation or warranty (other than as to title) has been given or will apply to the Products other than those in R&G's order or confirmation and the Buyer confirms it has chosen the Products as being of merchantable quality and suitable for its particular purposes. Where R&G fits the Products or undertakes other services it shall exercise reasonable skill and care and rectify any fault free of charge unless the workmanship has been disturbed. The Buyer is responsible for ensuring that the warranty on the motorcycle is not affected by the fitting of the Products. On return of any defective Products R&G shall at its option either supply a replacement or refund the purchase money but shall not be liable if the Products have been modified or used or maintained otherwise than in accordance with R&G's or manufacturer's instructions and good engineering practice or if the defect arises from accident or neglect. Other than identified above and subject to R&G not limiting its liability for causing death and personal injury, it shall not be liable for indirect or consequential loss and



otherwise its liability shall be limited to the amounts paid by the Buyer for the Products or the fitting or service concerned. These terms do not affect the Buyer's statutory rights.

R&G RACING RETURNS POLICY (NON-FAULTY GOODS)

Returns must be pre-authorised (if not pre-authorised the return will be rejected). Goods may only be returned direct to us if they were purchased direct from us (customer must prove if necessary). Otherwise to be returned to original vendor. Goods must be in re-sellable condition, in the opinion of R&G Racing. All returns are subject to a 25% restocking and handling fee (25% of the gross value exc. P&P – at the prevailing price at time of purchase). The customer must pay any and all carriage charges. No returns of discontinued products, unless within 14 days of purchase. This policy does not affect your statutory rights and does not refer to faulty goods.



NOTICE DE MONTAGE POUR LGFK0020C KIT GARDE LEVIER
KAWASAKI H2 SX 2018-



ASSUREZ VOUS DE LA COMPATIBILITE DU PRODUIT AVANT DE DEMONTER OU DE MODIFIER QUOI QUE CE SOIT SUR LA MOTO.

Le kit contient les articles exposés ci-dessous, vérifier que toutes les pièces soient présentes avant de procéder au montage.

La façon dont le kit est emballé ne correspond pas forcément à la façon de monter les pièces sur la moto.

LES PARTIES PRESENTEES PEUVENT ETRE UNIQUEMENT REPRESENTATIVES (POUR LA CLARTE DES INSTRUCTIONS UNIQUEMENT)

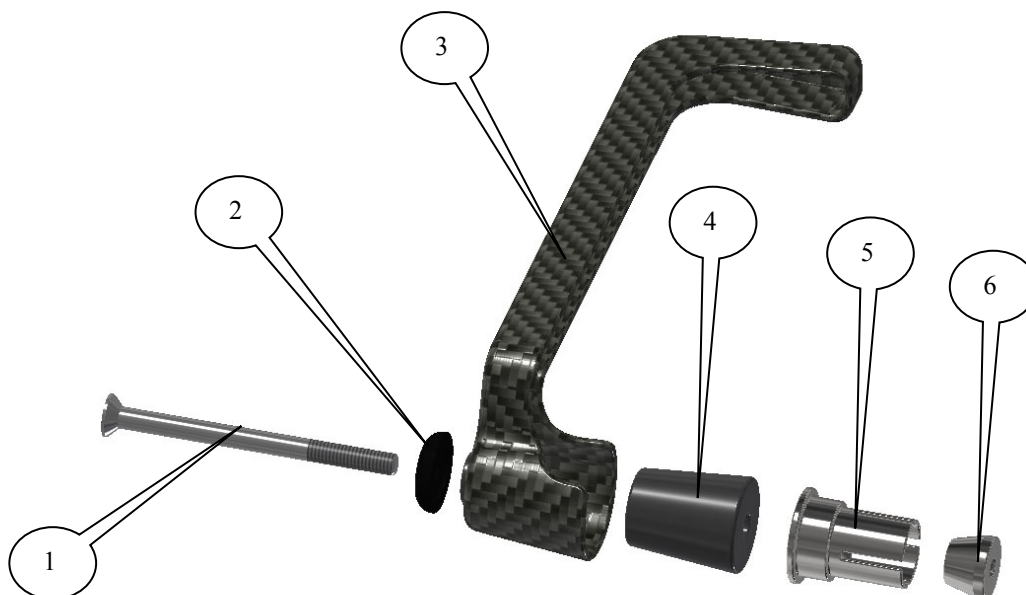



LEGENDE

- ARTICLE 1 = M6x80mm BOULON (x1).
- ARTICLE 2 = ENTRETOISE (S0928) (x1)
- ARTICLE 3 = PROTECTION POIGNEE EN CARBONE (NON INCLUSE DANS LE KIT) (LG0001) (x1).
- ARTICLE 4 = ENTRETOISE CONIQUE (S0781) (x1).
- ARTICLE 5 = EXPANDEUR (S0569) (x1).
- ARTICLE 6 = ÉCROU CONIQUE (H0032) (x1).

OUTILS REQUIS

- Jeu de clés Allen 4mm.
- Quelconque outil pour enlever l'extrémité d'origine du guidon

NOTICE DE MONTAGE

- Pour monter le Garde levier (article 2), enlever l'extrémité d'origine du guidon.
- Placer le boulon (article 1) dans le Garde levier.
- Placer l'entretoise d'extension (article 3) sur le filetage et sur le Garde levier de façon à ce que le diamètre le plus large se place contre le Garde levier.
- Placer l'écrou (article 4) sur le filetage et engagez jusqu'à ce qu'il se place dans l'écarteur tout juste monté.
- Placer l'ensemble dans le guidon et en position de façon à ce que le garde ne puis en aucun cas toucher une autre partie de la moto lorsque le guidon est verrouillé au maximum d'un coté ou de l'autre de la moto.
- Serrer complètement le boulon puis vérifier le fonctionnement.

IMPORTANT:

IL EST DE VOTRE RESPONSABILITE DE VERIFIER QUE CET ACCESSOIRE NE GENE EN AUCUN CAS LE BON FONCTIONNEMENT DE LA MOTO, ET DE VOUS ASSURER QU'IL SOIT TOUJOURS CORRECTEMENT SERRE ET OPERATIONNEL.

NE PAS EFFECTUER CES VERIFICATIONS PEUT ENTRAINER DES DEGATS SERIEUX TANT POUR LA MOTO QUE POUR LE MOTARD.

Notice disponible au téléchargement sur www.rg-racing.com

ISSUE 1 14/11/2018 (NSY)

CONSUMER NOTICE

The catalogue description and any exhibition of samples are only broad indications of the Products and R&G may make design changes which do not diminish their performance or visual appeal and supplying them in such state shall conform to the order. The Buyer acknowledges no representation or warranty (other than as to title) has been given or will apply to the Products other than those in R&G's order or confirmation and the Buyer confirms it has chosen the Products as being of merchantable quality and suitable for its particular purposes. Where R&G fits the Products or undertakes other services it shall exercise reasonable skill and care and rectify any fault free of charge unless the workmanship has been disturbed. The Buyer is responsible for ensuring that the warranty on the motorcycle is not affected by the fitting of the Products. On return of any defective Products R&G shall at its option either supply a replacement or refund the purchase money but shall not be liable if the Products have been modified or used or maintained otherwise than in accordance with R&G's or manufacturer's instructions and good engineering practice or if the defect arises from accident or neglect. Other than identified above and subject to R&G not limiting its liability for causing death and personal injury, it shall not be liable for indirect or consequential loss and otherwise its liability shall be limited to the amounts paid by the Buyer for the Products or the fitting or service concerned. These terms do not affect the Buyer's statutory rights.

R&G RACING RETURNS POLICY (NON-FAULTY GOODS)

Returns must be pre-authorized (if not pre-authorized the return will be rejected). Goods may only be returned direct to us if they were purchased direct from us (customer must prove if necessary). Otherwise to be returned to original vendor. Goods must be in re-sellable

R&G

Unit 1, Shelley's Lane, East Worldham, Alton, Hampshire, GU34 3AQ
Tel: +44 (0)1420 89007 Fax: +44 (0)1420 87301 www.rg-racing.com Email: info@rg-racing.com



LGFK0020C

condition, in the opinion of R&G Racing. All returns are subject to a 25% restocking and handling fee (25% of the gross value exc. P&P – at the prevailing price at time of purchase). The customer must pay any and all carriage charges. No returns of discontinued products, unless within 14 days of purchase. This policy does not affect your statutory rights and does not refer to