



**FITTING INSTRUCTIONS FOR LGFK0014 LEVER-GUARD FITTING KIT
TO FIT BMW G310R & GS 2017**

Page | 1



PLEASE ENSURE THAT THIS PRODUCT WILL FIT BEFORE ANY REMOVAL OR MODIFICATIONS OF PARTS ARE MADE TO YOUR MOTORCYCLE

**THIS KIT CONTAINS THE ITEMS PICTURED AND LABELLED BELOW.
DO NOT PROCEED UNTIL YOU ARE SURE ALL PARTS ARE PRESENT.**

Please note that the way the kit is packed does not necessarily represent the way of mounting to the bike

THE PARTS SHOWN MAY BE REPRESENTATIVE ONLY (FOR CLARITY OF INSTRUCTIONS ONLY)

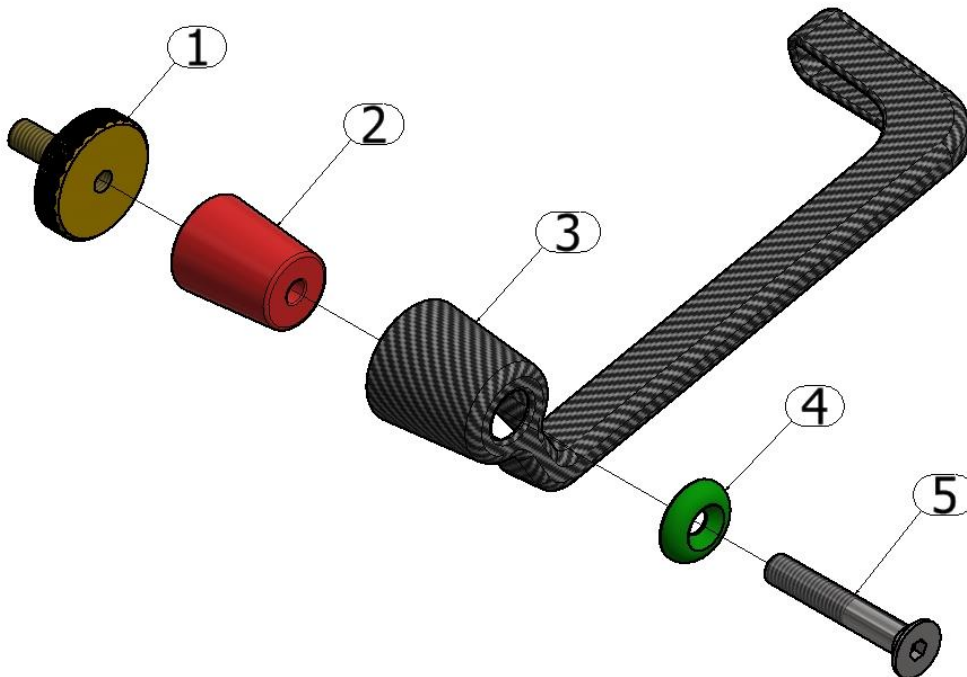

R&G

Unit 1 Shelleys Lane, East Worldham, Alton, Hants GU34 3AQ

Tel: +44 (0)1420 89007 Fax: +44 (0)1420 87301 www.rg-racing.com Email: info@rg-racing.com



LEGEND

ITEM 1 = MOUNTING BOSS (M0542) (x1)

ITEM 2 = LARGE CONE SPACER (S0781) (x1).

ITEM 3 = CARBON FIBRE LEVER GUARD (NOT INCLUDED IN FITTING KIT) (LG0001).

ITEM 4 = CLAMP SPACER (S0928) (x1).

ITEM 5 = M6 x 50mm LONG COUNTERSUNK BOLT (x1).

Page | 2

TOOLS REQUIRED

- Set of Allen keys to include 4mm A/F.
- Any tools required to remove original bar-end if applicable.

FITTING INSTRUCTIONS

- To fit the Lever Guard (item 3), remove the original bar end.
- Mount the protruded end of the mounting boss (Item 1) into the threaded boss in the handlebar. Fully tighten the mounting boss in position.
- Place the counter-sunk bolt (item 5) through domed counter-sunk spacer (item 4) and then through the Lever Guard so the domed spacer sits against fixed spacer in the Lever Guard.
- Place the large cone spacer (item 2) over the thread and into the Lever Guard.
- Locate the lever guard assembly into the threaded hole on the mounting boss (item 1) just fitted and position so when the motorcycle is at full lock in both directions it does not contact any other part of the motorcycle.
- Ensure that the assembled components match the exploded diagram shown in page 1.
- Fully tighten the bolt and check operation.

IMPORTANT:- WHEN FITTING THIS PRODUCT IT IS YOUR RESPONSIBILITY TO ENSURE THAT THE PRODUCT IN NO WAY IMPEDES THE OPERATION OF THE MOTORCYCLE AND IS CHECKED REGULARLY FOR TIGHTNESS AND OPERATION.

FAILURE TO CHECK THE ABOVE COULD RESULT IN SERIOUS INJURY OR DAMAGE.

Digital copies of these instructions are available to download from www.rg-racing.com

ISSUE 2 24/01/2018 (HH)

CONSUMER NOTICE

The catalogue description and any exhibition of samples are only broad indications of the Products and R&G may make design changes which do not diminish their performance or visual appeal and supplying them in such state shall conform to the order. The Buyer acknowledges no representation or warranty (other than as to title) has been given or will apply to the Products other than those in R&G's order or confirmation and the Buyer confirms it has chosen the Products as being of merchantable quality and suitable for its particular purposes. Where R&G fits the Products or undertakes other services it shall exercise reasonable skill and care and rectify any fault free of charge unless the workmanship has been disturbed. The Buyer is responsible for ensuring that the warranty on the motorcycle is not affected by the fitting of the Products. On return of any defective Products R&G shall at its option either supply a replacement or refund the purchase money but shall not be liable if the Products have been modified or used or maintained otherwise than in accordance with R&G's or manufacturer's instructions and good engineering practice or if the defect arises from accident or neglect. Other than identified above and subject to R&G not limiting its liability for causing death and personal injury, it shall not be liable for indirect or consequential loss and otherwise its liability shall be limited to the amounts paid by the Buyer for the Products or the fitting or service concerned. These terms do not affect the Buyer's statutory rights.

R&G RETURNS POLICY (NON-FAULTY GOODS)

Returns must be pre-authorized (if not pre-authorized the return will be rejected). Goods may only be returned direct to us if they were purchased direct from us (customer must prove if necessary). Otherwise to be returned to original vendor. Goods must be in re-sellable condition, in the opinion of R&G. All returns are subject to a 25% restocking and handling fee (25% of the gross value exc. P&P – at the prevailing price at time of purchase). The customer must pay any and all carriage charges. No returns of discontinued products, unless within 14 days of purchase. This policy does not affect your statutory rights and does not refer to faulty goods.

R&G

Unit 1 Shelleys Lane, East Worldham, Alton, Hants GU34 3AQ

Tel: +44 (0)1420 89007 Fax: +44 (0)1420 87301 www.rg-racing.com Email: info@rg-racing.com



NOTICE DE MONTAGE POUR LGFK0014
PROTECTION LEVIER DE FREIN
POUR BMW G310R & GS 2017



Page | 3

VERIFIER QUE LE PRODUIT SOIT COMPATIBLE AVEC VOTRE MOTO AVANT DE
 DEMONTER QUOI QUE CE SOIT.

**Le kit contient les articles exposés ci-dessous, vérifier que toutes les pièces soient présentes
 avant de procéder au montage.**

**La façon dont le kit est emballé ne correspond pas forcément à la façon de monter les pièces
 sur la moto.**

LES PARTIES PRESENTEES PEUVENT ETRE UNIQUEMENT REPRESENTATIVES (POUR LA
 CLARTE DES INSTRUCTIONS UNIQUEMENT)

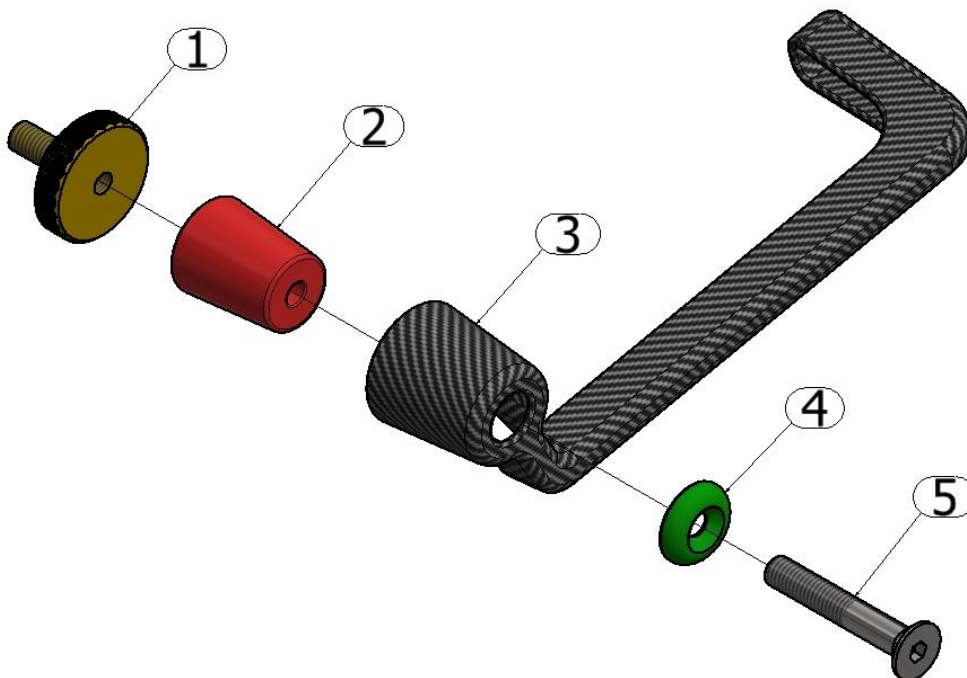

R&G

Unit 1 Shelleys Lane, East Worldham, Alton, Hants GU34 3AQ
 Tel: +44 (0)1420 89007 Fax: +44 (0)1420 87301 www.rg-racing.com Email: info@rg-racing.com



LÉGENDE

ARTICLE 1 = FILETAGE DE FIXATION (M0542) (x1)

ARTICLE 2 = ENTRETOISE CONIQUE (S0781) (x1).

ARTICLE 3 = PROTECTION LEVIER EN FIBRE DE CARBONE (NON INCLUS DANS LE KIT) (LG0001).

ARTICLE 4 = ENTRETOISE (S0928) (x1).

ARTICLE 5 = M6 x 50mm BOULON (x1).

Page | 4

OUTILS REQUIS

- Clés Allen 4mm F.
- Un outil adéquat pour enlever l'embout de guidon d'origine.

NOTICE DE MONTAGE

- Pour monter la protection levier (article 3), enlever l'embout de guidon d'origine.
- Monter l'extrémité dépassant du filetage de fixation (article 1) dans le filetage du guidon. Serrer complètement en position.
- Placer le boulon (article 5) dans l'entretoise (article 4) puis dans la protection levier de façon à ce que l'entretoise se place contre l'entretoise de la protection levier.
- Placer l'entretoise conique (article 2) sur le filetage puis dans la protection levier.
- Monter l'assemblage de protection levier en place dans le trou du filetage de fixation (article 1) tout juste monté puis positionner de façon à ce que lorsque le guidon est tourné au maximum d'un côté ou de l'autre, aucune partie ne soit touchée.
- Veiller à ce que l'ensemble corresponde au schéma de la page 1.
- Serrer complètement le boulon et vérifier le fonctionnement.

IMPORTANT : - IL EST DE VOTRE RESPONSABILITE DE CONTROLER QUE CE PRODUIT NE GENERA PAS LE FONCTIONNEMENT DE LA MOTO, ET DE VERIFIER REGULIEREMENT SON SERRAGE.

NE PAS EFFECTUER CES VERIFICATIONS PEUT CAUSER DES DOMMAGES POUR LA MOTO ET SON PILOTE.

Notice disponible au téléchargement sur www.rg-racing.com

ISSUE 2 24/01/2018 (HH)

CONSUMER NOTICE

The catalogue description and any exhibition of samples are only broad indications of the Products and R&G may make design changes which do not diminish their performance or visual appeal and supplying them in such state shall conform to the order. The Buyer acknowledges no representation or warranty (other than as to title) has been given or will apply to the Products other than those in R&G's order or confirmation and the Buyer confirms it has chosen the Products as being of merchantable quality and suitable for its particular purposes. Where R&G fits the Products or undertakes other services it shall exercise reasonable skill and care and rectify any fault free of charge unless the workmanship has been disturbed. The Buyer is responsible for ensuring that the warranty on the motorcycle is not affected by the fitting of the Products. On return of any defective Products R&G shall at its option either supply a replacement or refund the purchase money but shall not be liable if the Products have been modified or used or maintained otherwise than in accordance with R&G's or manufacturer's instructions and good engineering practice or if the defect arises from accident or neglect. Other than identified above and subject to R&G not limiting its liability for causing death and personal injury, it shall not be liable for indirect or consequential loss and otherwise its liability shall be limited to the amounts paid by the Buyer for the Products or the fitting or service concerned. These terms do not affect the Buyer's statutory rights.

R&G RETURNS POLICY (NON-FAULTY GOODS)

Returns must be pre-authorised (if not pre-authorised the return will be rejected). Goods may only be returned direct to us if they were purchased direct from us (customer must prove if necessary). Otherwise to be returned to original vendor. Goods must be in re-sellable condition, in the opinion of R&G. All returns are subject to a 25% restocking and handling fee (25% of the gross value exc. P&P – at the prevailing price at time of purchase). The customer must pay any and all carriage charges. No returns of discontinued products, unless within 14 days of purchase. This policy does not affect your statutory rights and does not refer to faulty goods.

R&G

Unit 1 Shelleys Lane, East Worldham, Alton, Hants GU34 3AQ

Tel: +44 (0)1420 89007 Fax: +44 (0)1420 87301 www.rg-racing.com Email: info@rg-racing.com



MONTAGEANLEITUNG FÜR LGFK0014 BREMSHEBELSCHUTZ-KIT
PASSEND FÜR BMW G310R & GS 2017



Page | 5

BITTE STELLEN SIE SICHER, DASS DIESES PRODUKT FÜR DIE MONTAGE AN IHREM MOTORRAD GEEIGNET IST, BEVOR DIE ENTFERNUNG ODER MODIFIKATION IRGENDWELCHER MOTORRADTEILE VORGENOMMEN WIRD.

ALLE KIT-TEILE SIND UNTEN ABGEBILDET UND GEKENNZEICHNET. ÜBERPRÜFEN SIE, DASS ALLE TEILE VORHANDEN SIND, BEVOR SIE MIT DER MONTAGE BEGINNEN.

Hinweis: Die Verpackung der Teile stellt nicht die Reihenfolge der Montage dar.

DIE UNTEN ABGEBILDETEN TEILE DIENEN LEDIGLICH ZUR ERKLÄRUNG

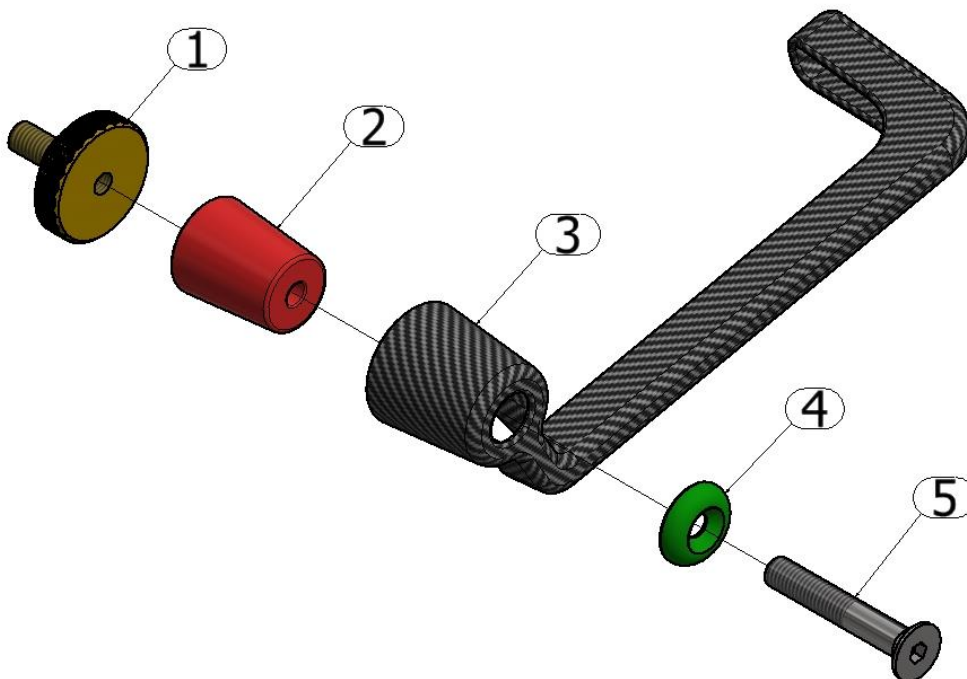

R&G

Unit 1 Shelleys Lane, East Worldham, Alton, Hants GU34 3AQ

Tel: +44 (0)1420 89007 Fax: +44 (0)1420 87301 www.rg-racing.com Email: info@rg-racing.com



LIEFERUMFANG

- ARTIKEL 1 = DISTANZHALTER MIT GEWINDE (M0542) (x1)
 ARTIKEL 2 = GROSSER DISTANZHALTER (KONUSFÖRMIG) (S0781) (x1)
 ARTIKEL 3 = BREMSHEBELSCHUTZ AUS CARBON (NICHT IM MONTAGEKIT ENTHALTEN) (LG0001)
 ARTIKEL 4 = DISTANZHALTER (S0928) (x1)
 ARTIKEL 5 = M6 x 50mm SENKKOPFSCHRAUBE (x1)

Page | 6

SIE BENÖTIGEN FOLGENDES WERKZEUG:

- Satz Inbusschlüssel mit 4mm Inbusschlüssel
- Werkzeug, um das original Lenkerende zu entfernen (falls zutreffend)

MONTAGEANLEITUNG

- Um den Bremshebelschutz (Artikel 3) zu montieren, entfernen Sie das original Lenkerende.
- Das hervorstehende Ende des Distanzhalters mit Gewinde (Artikel 1) am Gewindeeinsatz am Lenker montieren. Den Distanzhalter in Position befestigen.
- Führen Sie die Senkkopfschraube (Artikel 5) durch den Distanzhalter (Artikel 4) dann durch den Bremshebelschutz, so dass der Distanzhalter am fixierten Distanzhalter im Bremshebelschutz anliegt.
- Den großen Distanzhalter (konusförmig - Artikel 2) über das Gewinde in den Bremshebelschutz einführen.
- Die Einheit in der Gewindeöffnung am soeben montierten Distanzhalter mit Gewinde (Artikel 1) fixieren und so positionieren, dass keine Motorradteile berührt werden, wenn der Motorradlenker in beiden Richtungen komplett eingeschlagen ist.
- Bitte überprüfen Sie, dass der Zusammenbau der Teile der Explosionszeichnung auf Seite 1 entspricht.
- Ziehen Sie die Schraube fest und überprüfen Sie die Funktion des Bremshebels.

WICHTIG: BEI DER MONTAGES DES BREMSHEBELSCHUTZ-KITS LIEGT ES IN IHRER VERANTWORTUNG SICHERZUSTELLEN, DASS DAS PRODUKT DIE ORDNUNGSGEMÄSSE FUNKTION DER BREMSE BZW. DES MOTORRADES NICHT BEEINFLUSST ODER GEFÄHRDET. DIE FUNKTION UND FESTIGKEIT MUSS REGELMÄSSIG ÜBERPRÜFT WERDEN.

DIE NICHTBEACHTUNG DIESES SICHERHEITSHINWEISES KANN ZU SCHWEREN VERLETZUNGEN ODER BESCHÄDIGUNG FÜHREN.

Eine digitale Version dieser Montageanleitung kann auf folgender Seite heruntergeladen werden:

www.rg-racing.com

AUSGABE 2 24/01/2018 (HH)

CONSUMER NOTICE

The catalogue description and any exhibition of samples are only broad indications of the Products and R&G may make design changes which do not diminish their performance or visual appeal and supplying them in such state shall conform to the order. The Buyer acknowledges no representation or warranty (other than as to title) has been given or will apply to the Products other than those in R&G's order or confirmation and the Buyer confirms it has chosen the Products as being of merchantable quality and suitable for its particular purposes. Where R&G fits the Products or undertakes other services it shall exercise reasonable skill and care and rectify any fault free of charge unless the workmanship has been disturbed. The Buyer is responsible for ensuring that the warranty on the motorcycle is not affected by the fitting of the Products. On return of any defective Products R&G shall at its option either supply a replacement or refund the purchase money but shall not be liable if the Products have been modified or used or maintained otherwise than in accordance with R&G's or manufacturer's instructions and good engineering practice or if the defect arises from accident or neglect. Other than identified above and subject to R&G not limiting its liability for causing death and personal injury, it shall not be liable for indirect or consequential loss and otherwise its liability shall be limited to the amounts paid by the Buyer for the Products or the fitting or service concerned. These terms do not affect the Buyer's statutory rights.

R&G RETURNS POLICY (NON-FAULTY GOODS)

Returns must be pre-authorised (if not pre-authorised the return will be rejected). Goods may only be returned direct to us if they were purchased direct from us (customer must prove if necessary). Otherwise to be returned to original vendor. Goods must be in re-sellable condition, in the opinion of R&G. All returns are subject to a 25% restocking and handling fee (25% of the gross value exc. P&P - at the prevailing price at time of purchase). The customer must pay any and all carriage charges. No returns of discontinued products, unless within 14 days of purchase. This policy does not affect your statutory rights and does not refer to faulty goods.

R&G

Unit 1 Shelleys Lane, East Worldham, Alton, Hants GU34 3AQ

Tel: +44 (0)1420 89007 Fax: +44 (0)1420 87301 www.rg-racing.com Email: info@rg-racing.com