



**FITTING INSTRUCTIONS FOR LGFK0011**  
**LEVER-GUARD FITTING KIT**  
**TO FIT KAWASAKI Z650 & NINJA 650 2017-**

Page | 1



PLEASE ENSURE THAT THIS PRODUCT WILL FIT BEFORE ANY REMOVAL OR MODIFICATIONS OF PARTS ARE MADE TO YOUR MOTORCYCLE

**THIS KIT CONTAINS THE ITEMS PICTURED AND LABELLED BELOW.**  
**DO NOT PROCEED UNTIL YOU ARE SURE ALL PARTS ARE PRESENT.**

**Please note that the way the kit is packed does not necessarily represent the way of mounting to the bike**

THE PARTS SHOWN MAY BE REPRESENTATIVE ONLY (FOR CLARITY OF INSTRUCTIONS ONLY)

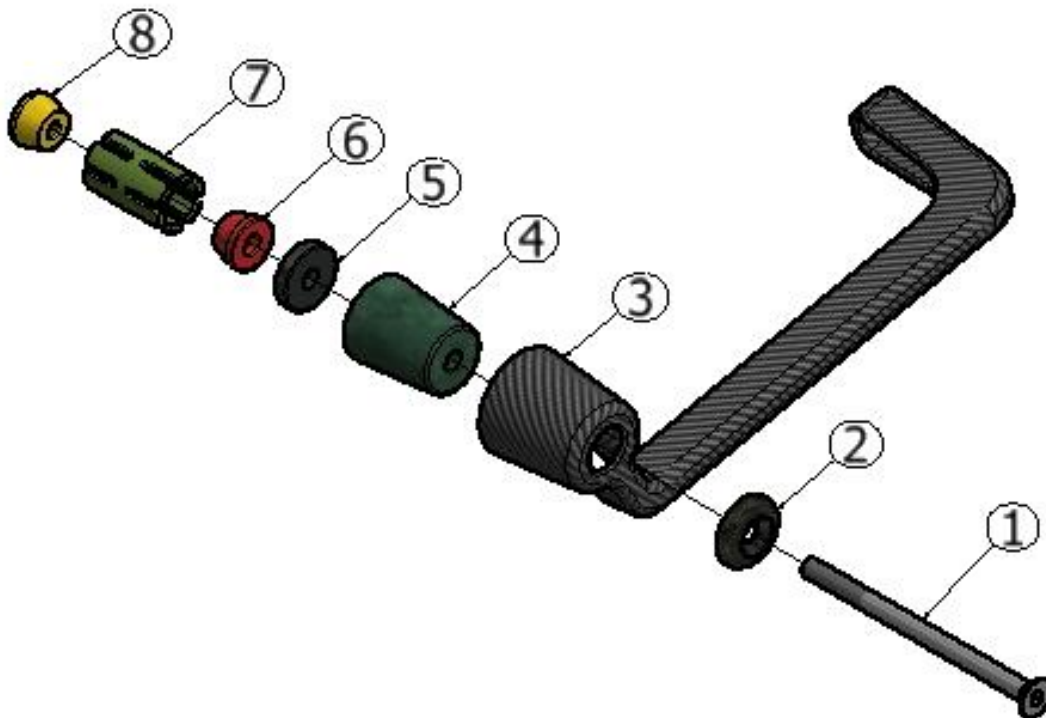

**R&G Racing**

Unit 1 Shelleys Lane, East Worldham, Alton, Hants GU34 3AQ

Tel: +44 (0)1420 89007 Fax: +44 (0)1420 87301 [www.rg-racing.com](http://www.rg-racing.com) Email: [info@rg-racing.com](mailto:info@rg-racing.com)



## **LEGEND**

- ITEM 1 = M6 x 90mm LONG COUNTERSUNK BOLT (x1)  
 ITEM 2 = CLAMP SPACER (S0928) (x1)  
 ITEM 3 = CARBON LEVER GUARD (NOT INCLUDED IN FITTING KIT) (LG0001) (x1).  
 ITEM 4 = CONE SPACER (S0781) (x1)  
 ITEM 5 = HANDLE-BAR SPACER (S1033) (x1)  
 ITEM 6 = EXPANDER SPACER (S0841) (x1)  
 ITEM 7 = EXPANDER (S0839) (x1)  
 ITEM 8 = TAPERED NUT (H0056) (x1)

Page | 2

## **TOOLS REQUIRED**

- Set of Allen keys to include 4mm A/F.
- Any tools required to remove original bar-end if applicable.

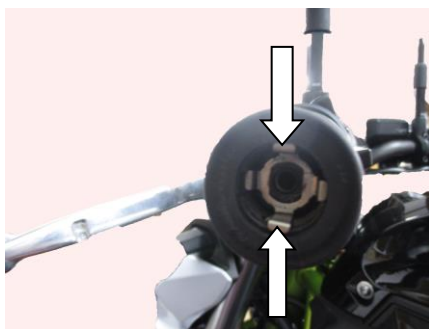

PICTURE 1

## **FITTING INSTRUCTIONS**

- To fit the Lever Guard the original bar end needs to be removed. Roll up the end of handle-bar grip inwards so the tip of OEM slider clips can be seen (in the handle-bar). Spray the OEM slider assembly with appropriate lubricant, this is to help to slide the whole slider assembly out. Using appropriate tools, please push in the two exposed slider clips inwards (as shown in Picture 1) while at the same time pulling the bar end/ slider assembly out.
- Place the counter-sunk bolt (Item 1) through the clamp spacer (Item 2) and then through the Lever Guard (Item 3) so the flat face of the spacer sits against the front face of the lever guard as shown in the exploded diagram.
- Insert the cone spacer (Item 4) through the protruded end of the bolt so the spacer sits inside the lever guard.
- Insert the handle bar spacer (Item 5) through the protruded end of the bolt, follow by the expander spacer. Ensure that the flat face of the expander spacer (Item 6) sits against the handle-bar spacer (Item 5).
- Insert the Expander (Item 7) through the protruded end of the bolt, follow by the tapered nut (Item 8). Ensure that the tapered nut sits in the expander. Do not fully tighten the nut into the expander at this stage.
- Offer the whole assembly into the handle-bar until the handle-bar spacer (Item 5) sits against the face of the handle-bar tube.
- Position the lever guard so when the handle bar is at full lock in both directions it does not make any contact with any other part of the motorcycle.
- Fully tighten the bolt and check operation.

**IMPORTANT**:- WHEN FITTING THIS PRODUCT IT IS YOUR RESPONSIBILITY TO ENSURE THAT THE PRODUCT IN NO WAY IMPEDES

## **R&G Racing**

Unit 1 Shelleys Lane, East Worldham, Alton, Hants GU34 3AQ

Tel: +44 (0)1420 89007 Fax: +44 (0)1420 87301 [www.rg-racing.com](http://www.rg-racing.com) Email: [info@rg-racing.com](mailto:info@rg-racing.com)



THE OPERATION OF THE MOTORCYCLE AND IS CHECKED REGULARLY FOR TIGHTNESS AND OPERATION.

FAILURE TO CHECK THE ABOVE COULD RESULT IN SERIOUS INJURY OR DAMAGE.

Page | 3

**Digital copies of these instructions are available to download from [www.rg-racing.com](http://www.rg-racing.com)**

ISSUE 1 03/07/2017 (HH)

#### **CONSUMER NOTICE**

The catalogue description and any exhibition of samples are only broad indications of the Products and R&G may make design changes which do not diminish their performance or visual appeal and supplying them in such state shall conform to the order. The Buyer acknowledges no representation or warranty (other than as to title) has been given or will apply to the Products other than those in R&G's order or confirmation and the Buyer confirms it has chosen the Products as being of merchantable quality and suitable for its particular purposes. Where R&G fits the Products or undertakes other services it shall exercise reasonable skill and care and rectify any fault free of charge unless the workmanship has been disturbed. The Buyer is responsible for ensuring that the warranty on the motorcycle is not affected by the fitting of the Products. On return of any defective Products R&G shall at its option either supply a replacement or refund the purchase money but shall not be liable if the Products have been modified or used or maintained otherwise than in accordance with R&G's or manufacturer's instructions and good engineering practice or if the defect arises from accident or neglect. Other than identified above and subject to R&G not limiting its liability for causing death and personal injury, it shall not be liable for indirect or consequential loss and otherwise its liability shall be limited to the amounts paid by the Buyer for the Products or the fitting or service concerned. These terms do not affect the Buyer's statutory rights.

#### **R&G RACING RETURNS POLICY (NON-FAULTY GOODS)**

Returns must be pre-authorised (if not pre-authorised the return will be rejected). Goods may only be returned direct to us if they were purchased direct from us (customer must prove if necessary). Otherwise to be returned to original vendor. Goods must be in re-sellable condition, in the opinion of R&G Racing. All returns are subject to a 25% restocking and handling fee (25% of the gross value exc. P&P – at the prevailing price at time of purchase). The customer must pay any and all carriage charges. No returns of discontinued products, unless within 14 days of purchase. This policy does not affect your statutory rights and does not refer to faulty goods.

### **R&G Racing**

Unit 1 Shelleys Lane, East Worldham, Alton, Hants GU34 3AQ

Tel: +44 (0)1420 89007 Fax: +44 (0)1420 87301 [www.rg-racing.com](http://www.rg-racing.com) Email: [info@rg-racing.com](mailto:info@rg-racing.com)



**NOTICE DE MONTAGE POUR LGFK0011**  
**PROTECTION POIGNEE DE FREIN**  
**POUR KAWASAKI Z650 & NINJA 650 2017-**

Page | 4



VERIFIER QUE LE PRODUIT SOIT COMPATIBLE AVEC VOTRE MOTO AVANT DE  
 DEMONTER QUOI QUE CE SOIT.

**Le kit contient les articles exposés ci-dessous, vérifier que toutes les pièces soient présentes avant de  
 procéder au montage.**

**La façon dont le kit est emballé ne correspond pas forcément à la façon de monter les pièces sur la moto.**

LES PARTIES PRESENTEES PEUVENT ETRE UNIQUEMENT REPRESENTATIVES (POUR LA  
 CLARTE DES INSTRUCTIONS UNIQUEMENT)

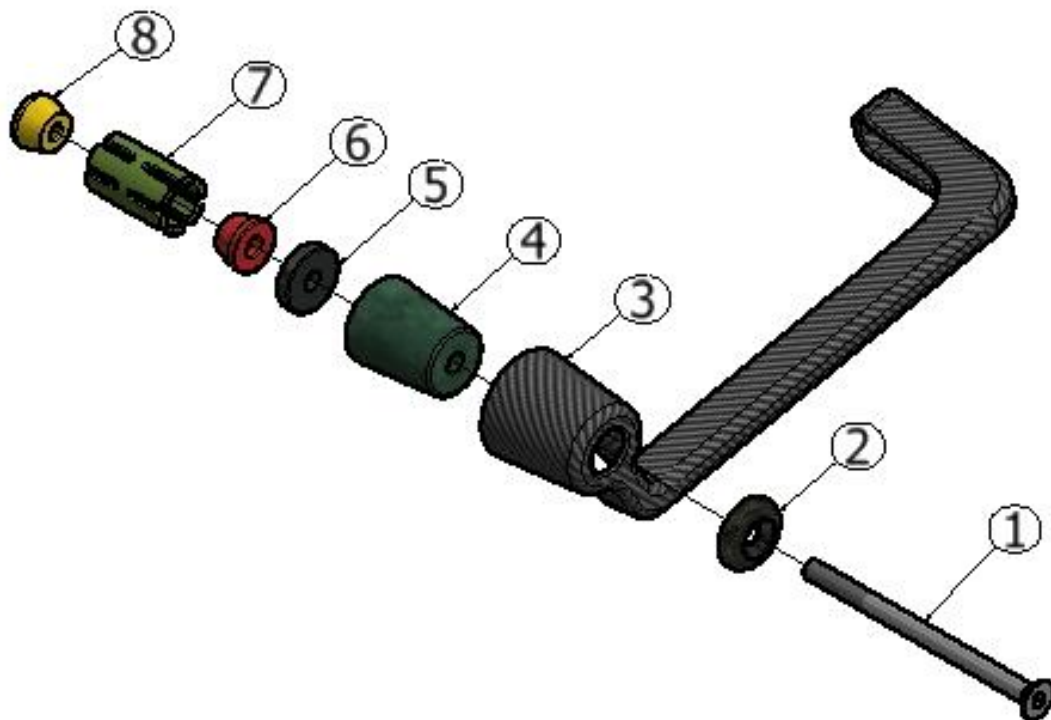

**R&G Racing**

Unit 1 Shelleys Lane, East Worldham, Alton, Hants GU34 3AQ

Tel: +44 (0)1420 89007 Fax: +44 (0)1420 87301 [www.rg-racing.com](http://www.rg-racing.com) Email: [info@rg-racing.com](mailto:info@rg-racing.com)



## LEGEND

- ARTICLE 1 = M6 x 90mm BOULON (x1)  
 ARTICLE 2 = ENTRETOISE (S0928) (x1)  
 ARTICLE 3 = PROTECTION POIGNEE EN CARBONE (NON INCLUSE DANS LE KIT) (LG0001) (x1).  
 ARTICLE 4 = ENTRETOISE CONIQUE (S0781) (x1)  
 ARTICLE 5 = ENTRETOISE DE GUIDON (S1033) (x1)  
 ARTICLE 6 = ENTRETOISE D'EXTENSION (S0841) (x1)  
 ARTICLE 7 = EXPANDEUR (S0839) (x1)  
 ARTICLE 8 = ÉCROU CONIQUE (H0056) (x1)

Page | 5

## OUTILS REQUIS

- Clés Allen 4mm.
- Un outil adéquat pour enlever l'embout de guidon d'origine.

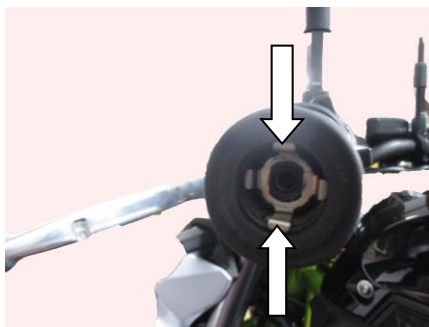

PHOTO 1

## NOTICE DE MONTAGE

- Pour monter le protection poignée, l'extrémité de guidon d'origine doit être enlevée. Rouler l'extrémité de la poignée du guidon vers l'intérieur de sorte que la pointe des clips de glissière d'origine puisse être vue (dans le guidon). Pulvériser l'ensemble d'origine avec un lubrifiant approprié, cela permettra de faciliter la glisse de l'ensemble pour le retirer. A l'aide d'outils appropriés, appuyez sur les deux clips de slider exposés vers l'intérieur (voir Picture 1) tout en tirant l'extrémité du guidon/l'ensemble de slider vers l'extérieur.
- Placer le boulon (Article 1) dans l'entretoise (Article 2) puis dans la protection poignée (Article 3) de façon à ce que la face plate de l'entretoise se place contre la face avant de la protection poignée, voir le schéma.
- Insérer l'entretoise conique (Article 4) dans l'extrémité visible du boulon de façon à ce que l'entretoise se place à l'intérieur de la protection poignée.
- Insérer l'entretoise de guidon (Article 5) sur l'extrémité visible du boulon, suivi d'une entretoise d'extension. Veiller à ce que la partie plate de l'entretoise d'extension (Article 6) se place contre l'entretoise de guidon (Article 5).
- Insérer l'expandeur (Article 7) sur l'extrémité visible du boulon, suivi d'un écrou conique (Article 8). Veiller à ce que l'écrou conique se place dans l'expandeur. Ne pas serrer complètement l'écrou dans l'expandeur à ce stade du montage.
- Monter l'ensemble sur le guidon jusqu'à ce que l'entretoise de guidon (Article 5) se place contre la face du tube de guidon.
- Positionner la protection poignée de façon à ce que lorsque le guidon est tourné au maximum des 2 côtés, aucun contact ne soit possible entre le guidon et une autre partie de la moto.
- Serrer complètement le boulon et vérifier le fonctionnement.

## **R&G Racing**

Unit 1 Shelleys Lane, East Worldham, Alton, Hants GU34 3AQ

Tel: +44 (0)1420 89007 Fax: +44 (0)1420 87301 [www.rg-racing.com](http://www.rg-racing.com) Email: [info@rg-racing.com](mailto:info@rg-racing.com)



**IMPORTANT** : - IL EST DE VOTRE RESPONSABILITE DE CONTROLER QUE CE PRODUIT NE GENERA PAS LE FONCTIONNEMENT DE LA MOTO, ET DE VERIFIER REGULIEREMENT SON SERRAGE.

NE PAS EFFECTUER CES VERIFICATIONS PEUT CAUSER DES DOMMAGES POUR LA MOTO ET SON PILOTE.

Page | 6

**Notice disponible au téléchargement sur [www.rg-racing.com](http://www.rg-racing.com)**

ISSUE 1 03/07/2017 (HH)

#### **CONSUMER NOTICE**

The catalogue description and any exhibition of samples are only broad indications of the Products and R&G may make design changes which do not diminish their performance or visual appeal and supplying them in such state shall conform to the order. The Buyer acknowledges no representation or warranty (other than as to title) has been given or will apply to the Products other than those in R&G's order or confirmation and the Buyer confirms it has chosen the Products as being of merchantable quality and suitable for its particular purposes. Where R&G fits the Products or undertakes other services it shall exercise reasonable skill and care and rectify any fault free of charge unless the workmanship has been disturbed. The Buyer is responsible for ensuring that the warranty on the motorcycle is not affected by the fitting of the Products. On return of any defective Products R&G shall at its option either supply a replacement or refund the purchase money but shall not be liable if the Products have been modified or used or maintained otherwise than in accordance with R&G's or manufacturer's instructions and good engineering practice or if the defect arises from accident or neglect. Other than identified above and subject to R&G not limiting its liability for causing death and personal injury, it shall not be liable for indirect or consequential loss and otherwise its liability shall be limited to the amounts paid by the Buyer for the Products or the fitting or service concerned. These terms do not affect the Buyer's statutory rights.

#### **R&G RACING RETURNS POLICY (NON-FAULTY GOODS)**

Returns must be pre-authorized (if not pre-authorized the return will be rejected). Goods may only be returned direct to us if they were purchased direct from us (customer must prove if necessary). Otherwise to be returned to original vendor. Goods must be in re-sellable condition, in the opinion of R&G Racing. All returns are subject to a 25% restocking and handling fee (25% of the gross value exc. P&P – at the prevailing price at time of purchase). The customer must pay any and all carriage charges. No returns of discontinued products, unless within 14 days of purchase. This policy does not affect your statutory rights and does not refer to faulty goods.

### **R&G Racing**

Unit 1 Shelleys Lane, East Worldham, Alton, Hants GU34 3AQ

Tel: +44 (0)1420 89007 Fax: +44 (0)1420 87301 [www.rg-racing.com](http://www.rg-racing.com) Email: [info@rg-racing.com](mailto:info@rg-racing.com)