



**FITTING INSTRUCTIONS FOR LGFK0003 LEVER-GUARD FITTING KIT
TO FIT KAWASAKI ZX6/ZX10 2004-**



Page | 1

PLEASE ENSURE THAT THIS PRODUCT WILL FIT BEFORE ANY REMOVAL OR MODIFICATIONS OF PARTS ARE MADE TO YOUR MOTORCYCLE

**THIS KIT CONTAINS THE ITEMS PICTURED AND LABELLED BELOW.
DO NOT PROCEED UNTIL YOU ARE SURE ALL PARTS ARE PRESENT.**

Please note that the way the kit is packed does not necessarily represent the way of mounting to the bike

THE PARTS SHOWN MAY BE REPRESENTATIVE ONLY (FOR CLARITY OF INSTRUCTIONS ONLY)

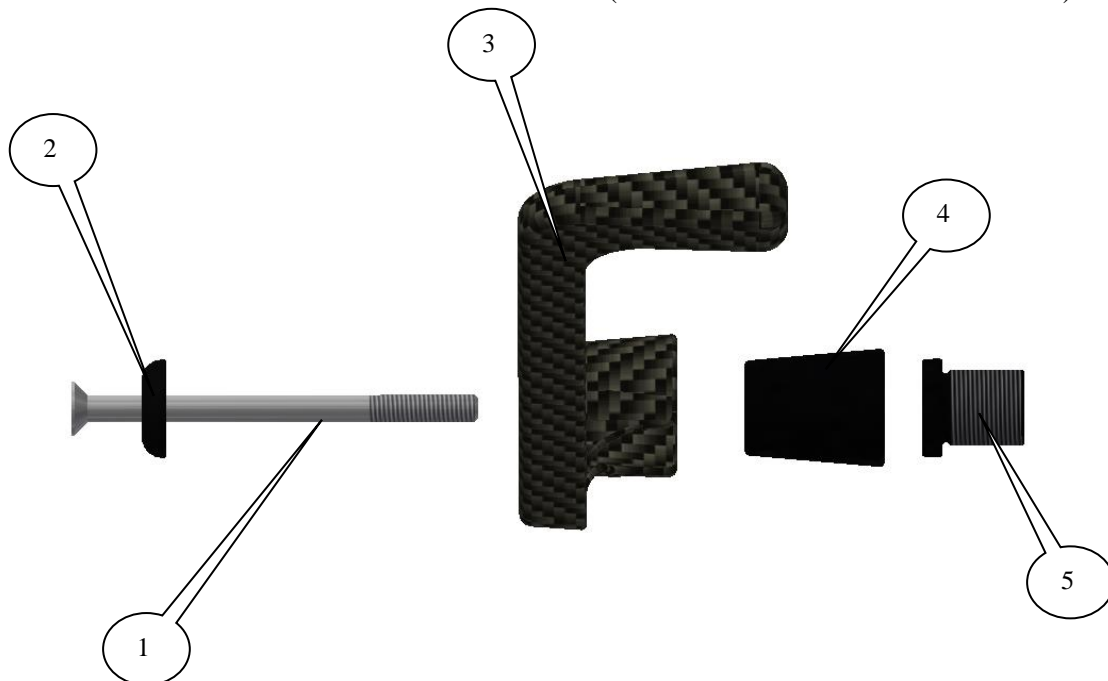

R&G Racing

Unit 1 Shelleys Lane, East Worldham, Alton, Hants GU34 3AQ

Tel: +44 (0)1420 89007 Fax: +44 (0)1420 87301 www.rg-racing.com Email: info@rg-racing.com



LEGEND

ITEM 1 = M6x60mm LONG COUNTER-SUNK BOLT (x1).

ITEM 2 = CLAMP SPACER (S0928) (x1).

ITEM 3 = CARBON FIBRE LEVER GUARD (NOT INCLUDED IN FITTING KIT) (LG0001).

ITEM 4 = LARGE CONE SPACER (S0781) (x1).

ITEM 5 = THREADED SPACER (S0856) (x1).

Page | 2

TOOLS REQUIRED

- Set of Allen keys to include 4mm A/F.
 - 19mm A/F Spanner or Socket
- Whatever tools required to remove original bar-end if applicable.

FITTING INSTRUCTIONS

- To fit the Lever Guard (item 3) remove the original bar end.
- Insert and tighten the threaded spacer (item 5) into the bar.
- Place the counter-sunk bolt (item 1) through domed counter-sunk spacer (item 2) and then through the Lever Guard so the domed spacer sits against fixed spacer in the Lever Guard.
- Place the large cone spacer (item 4) over the thread and into the Lever Guard.
- Locate the assembly into the threaded spacer and position so when the motorcycle is at full lock in both directions it does not contact any other part of the motorcycle.
- Fully tighten the bolt and check operation.

IMPORTANT:- WHEN FITTING THIS PRODUCT IT IS YOUR RESPONSIBILITY TO ENSURE THAT THE PRODUCT IN NO WAY IMPEDES THE OPERATION OF THE MOTOR CYCLE AND IS CHECKED REGULARLY FOR TIGHTNESS AND OPERATION.

FAILURE TO CHECK THE ABOVE COULD RESULT IN SERIOUS INJURY OR DAMAGE.

Digital copies of these instructions are available to download from www.rg-racing.com

ISSUE 1 20/01/2016 (NSY)

CONSUMER NOTICE

The catalogue description and any exhibition of samples are only broad indications of the Products and R&G may make design changes which do not diminish their performance or visual appeal and supplying them in such state shall conform to the order. The Buyer acknowledges no representation or warranty (other than as to title) has been given or will apply to the Products other than those in R&G's order or confirmation and the Buyer confirms it has chosen the Products as being of merchantable quality and suitable for its particular purposes. Where R&G fits the Products or undertakes other services it shall exercise reasonable skill and care and rectify any fault free of charge unless the workmanship has been disturbed. The Buyer is responsible for ensuring that the warranty on the motorcycle is not affected by the fitting of the Products. On return of any defective Products R&G shall at its option either supply a replacement or refund the purchase money but shall not be liable if the Products have been modified or used or maintained otherwise than in accordance with R&G's or manufacturer's instructions and good engineering practice or if the defect arises from accident or neglect. Other than identified above and subject to R&G not limiting its liability for causing death and personal injury, it shall not be liable for indirect or consequential loss and otherwise its liability shall be limited to the amounts paid by the Buyer for the Products or the fitting or service concerned. These terms do not affect the Buyer's statutory rights.

R&G RACING RETURNS POLICY (NON-FAULTY GOODS)

Returns must be pre-authorised (if not pre-authorised the return will be rejected). Goods may only be returned direct to us if they were purchased direct from us (customer must prove if necessary). Otherwise to be returned to original vendor. Goods must be in re-sellable condition, in the opinion of R&G Racing. All returns are subject to a 25% restocking and handling fee (25% of the gross value exc. P&P – at the prevailing price at time of purchase). The customer must pay any and all carriage charges. No returns of discontinued products, unless within 14 days of purchase. This policy does not affect your statutory rights and does not refer to faulty goods.

R&G Racing

Unit 1 Shelleys Lane, East Worldham, Alton, Hants GU34 3AQ

Tel: +44 (0)1420 89007 Fax: +44 (0)1420 87301 www.rg-racing.com Email: info@rg-racing.com



INSTRUCTIONS DE MONTAGE POUR LGFK0003 KIT DE PROTECTION
POIGNEE DE FREIN
POUR KAWASAKI ZX6/ZX10 2004-

Page | 3



VEILLER A CE QUE CE PRODUIT PUISSE SE FIXER AVANT D'ENLEVER OU DE
 MODIFIER QUOI QUE CE SOIT DE LA MOTO

**Le kit contient les articles exposés ci-dessous, vérifier que toutes les pièces soient présentes avant de
 procéder au montage.**

La façon dont le kit est emballé ne correspond pas forcément à la façon de monter les pièces sur la moto.

**LES PARTIES PRESENTEES PEUVENT ETRE UNIQUEMENT REPRESENTATIVES (POUR LA
 CLARTE DES INSTRUCTIONS UNIQUEMENT)**

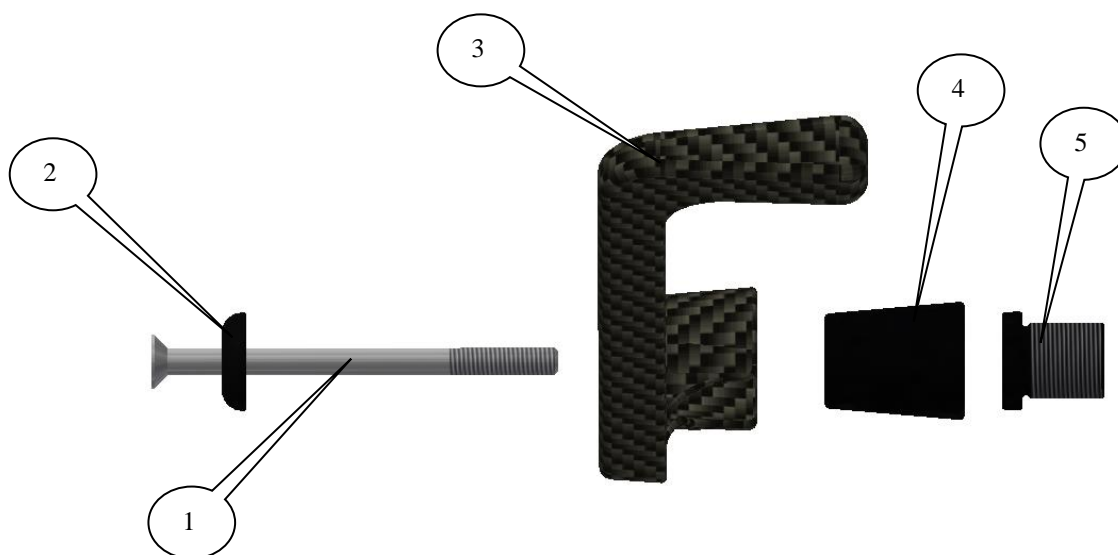

R&G Racing

Unit 1 Shelleys Lane, East Worldham, Alton, Hants GU34 3AQ

Tel: +44 (0)1420 89007 Fax: +44 (0)1420 87301 www.rg-racing.com Email: info@rg-racing.com



LEGENDE

ARTICLE 1 = M6x60mm BOULON (x1).

ARTICLE 2 = ENTRETOISE (S0928) (x1).

ARTICLE 3 = PROTECTION POIGNEE EN FIBRE DE CARBONE (NON INCLUE DANS LE KIT DE MONTAGE) (LG0001).

ARTICLE 4 = ENTRETOISE CONIQUE (S0781) (x1).

ARTICLE 5 = ENTRETOISE FILETEE (S0856) (x1).

OUTILS REQUIS

- Jeu de clés Allen 4mm.
 - Clé de 19mm
- Un outil adapté pour enlever la barre d'origine.

INSTRUCTIONS DE MONTAGE

- Pour installer la protection levier (article 3) enlever l'axe d'origine.
- Insérer puis serrer l'entretoise fileté (article 5) dans l'axe.
- Placer le boulon (article 1) dans l'entretoise bombée (article 2) puis dans le garde levier afin que l'entretoise bombée se place contre l'entretoise fixée dans le garde levier.
- Placer l'entretoise conique (article 4) sur le filetage puis dans le levier.
- Placer l'ensemble dans l'entretoise fileté puis positionnez-le de façon à ce qu'il ne puisse pas toucher la moto lorsque le guidon est tourné au maximum, à gauche et à droite.
- Serrer le boulon puis vérifier le fonctionnement.

IMPORTANT:

LORSQUE VOUS INSTALLEZ CE PRODUIT, IL EST DE VOTRE RESPONSABILITE DE CONTROLER QUE LE PRODUIT N'ALTERE EN AUCUN CAS LE FONCTIONNEMENT DE LA MOTO, ET DE VERIFIER LE SERRAGE REGULIEREMENT.

NE PAS EFFECTUER CES VERIFICATIONS PEUT CAUSER DES DOMMAGES IMPROTANTS, TANT POUR LA MOTO QUE POUR LE PILOTE.

Ces instructions de montage sont disponibles sur www.rg-racing.com

ISSUE 1 20/01/2016 (NSY)

CONSUMER NOTICE

The catalogue description and any exhibition of samples are only broad indications of the Products and R&G may make design changes which do not diminish their performance or visual appeal and supplying them in such state shall conform to the order. The Buyer acknowledges no representation or warranty (other than as to title) has been given or will apply to the Products other than those in R&G's order or confirmation and the Buyer confirms it has chosen the Products as being of merchantable quality and suitable for its particular purposes. Where R&G fits the Products or undertakes other services it shall exercise reasonable skill and care and rectify any fault free of charge unless the workmanship has been disturbed. The Buyer is responsible for ensuring that the warranty on the motorcycle is not affected by the fitting of the Products. On return of any defective Products R&G shall at its option either supply a replacement or refund the purchase money but shall not be liable if the Products have been modified or used or maintained otherwise than in accordance with R&G's or manufacturer's instructions and good engineering practice or if the defect arises from accident or neglect. Other than identified above and subject to R&G not limiting its liability for causing death and personal injury, it shall not be liable for indirect or consequential loss and otherwise its liability shall be limited to the amounts paid by the Buyer for the Products or the fitting or service concerned. These terms do not affect the Buyer's statutory rights.

R&G RACING RETURNS POLICY (NON-FAULTY GOODS)

Returns must be pre-authorized (if not pre-authorized the return will be rejected). Goods may only be returned direct to us if they were purchased direct from us (customer must prove if necessary). Otherwise to be returned to original vendor. Goods must be in re-sellable condition, in the opinion of R&G Racing. All returns are subject to a 25% restocking and handling fee (25% of the gross value exc. P&P – at the prevailing price at time of purchase). The customer must pay any and all carriage charges. No returns of discontinued products, unless within 14 days of purchase. This policy does not affect your statutory rights and does not refer to faulty goods.

R&G Racing

Unit 1 Shelleys Lane, East Worldham, Alton, Hants GU34 3AQ

Tel: +44 (0)1420 89007 Fax: +44 (0)1420 87301 www.rg-racing.com Email: info@rg-racing.com