

Note!

21801-01 and 21802-01 to be used in 2002-2005 models only.

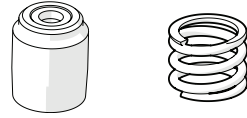

Kit Contents

Description	Part No	Pcs
Cartridge kit	FKC101	1
Sticker top cap screw	00191-49	2
Sticker	01185-04	2
Owner's manual	07288-01	1
Top out spring, see note	21801-01	1
Oil lock sleeve, see note	21802-01	1

Note!

Please note that there can be small differences between your product and the images in these instructions.

Note!

Please note that during storage and transport, especially at high ambient temperature, some of the oil and grease used for assembly may leak and stain the packaging. This will not cause damage to the product, wipe off the excessive oil or grease with a cloth.

Note!

Before you install this product, check the kit contents. If anything is missing, please contact an Öhlins dealer.

Warning!

Before you install this product, read the Öhlins Owner's manual. This product is an important part of the vehicle and the vehicle stability.

Cartridge kit for Harley-Davidson Touring FLHx/ FLTx 1997 - 2013

FKC 101

Mounting Instructions



MOUNTING INSTRUCTIONS

⚠ Warning!

We strongly recommend to let an Öhlins dealer install this product.

⚠ Warning!

If you work with a lifted vehicle, make sure that it is safely supported to prevent it from tipping over.

👁 Note!

When you work with this product, see the vehicle service manual for vehicle specific procedures and important data.

👁 Note!

Before you install this product clean the vehicle.

Tool	Part no	
Pull-up tool	01765-08	
Stopper plate	02810-03	
Wrench		13 mm
Open end wrench		13/16"
Open end torque wrench		13/16"
Allen key		6 mm
Allen key torque wrench		6 mm

YM 2002-2005 specific tools

Wrench 14 mm

Appropriate flat-head screwdriver to remove oil seal clip

Oil seal installation tool 41 mm

Oil seal grease according to vehicle service manual

Before you begin

The kit consists of one compression cartridge and one rebound cartridge. Make sure you install each cartridge in the correct fork leg.

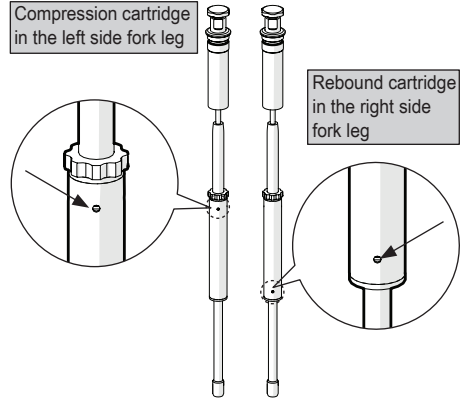

Remove the original damping system

1

Remove the front fork from the vehicle according to the vehicle service manual.

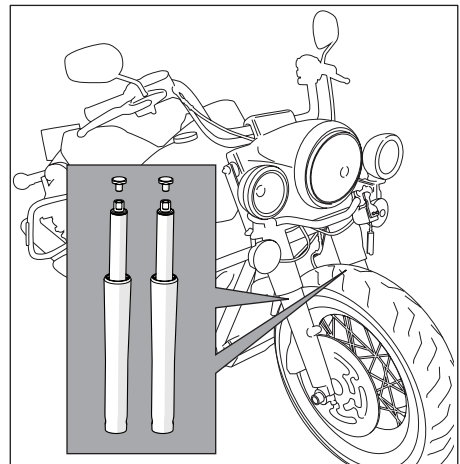

MOUNTING INSTRUCTIONS

👁 **Note!**

For MY 2002-2005, this model has damping rod in one leg and cartridge kit in the other leg, see page 3 for damping rod and page 4-5 for cartridge kit

⚠ **Warning!**

Spring compression creates a potential danger because of the violent force that loaded springs are capable of.

Important: When you remove the top cap push down the top cap and at the same time pull up the inner tube to prevent uncontrolled release.

2

Use a 13/16" open end wrench to loosen and remove the top cap from the inner tube.

Important: When you remove the top cap push down the top cap and at the same time pull up the inner tube to prevent uncontrolled release.

3

Remove the main spring.

👁 **Note!**

When you work with the fork leg, make sure that the inner tube (A) is at lowest position to keep the oil lock sleeve (B) correctly positioned inside the inner tube.

4

Drain the fork leg from oil.

5

Use a 6 mm Allen key to remove the bottom screw. Make sure not to lose the washer.

6

Remove the damping rod from the fork leg. Do not remove the top out spring. If the top out spring falls out with the damping rod, put it back in the fork leg.

Lowering kit 08865-01 only:

Install the spacer (21803-01) (A) and the top out spring (B) in the fork leg.

👋 **Caution!**

Make sure to install the spacer and the spring in the correct order.

Lowering kit
08865-01:

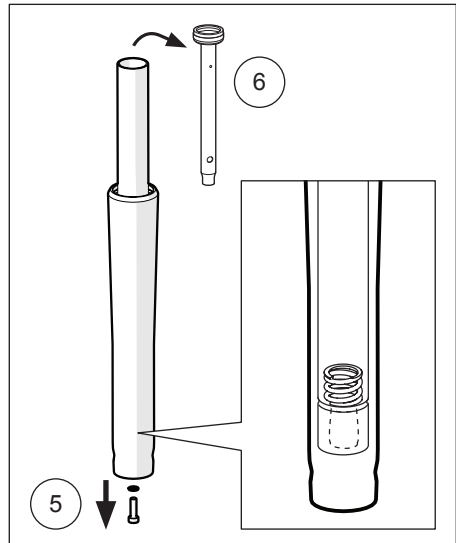
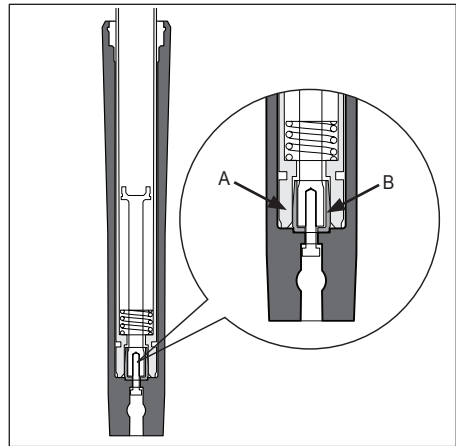
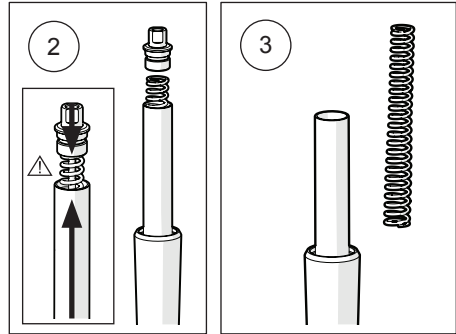
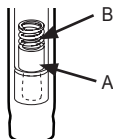

MOUNTING INSTRUCTIONS

Remove the damping system MY 2002-2005

⚠ Warning!

Spring compression creates a potential danger because of the violent force that loaded springs are capable of.

Important: When you remove the top cap push down the top cap and at the same time pull up the inner tube to prevent uncontrolled release.

2

Use a 13/16" open end wrench to loosen the top cap from the inner tube.

Important: When you remove the top cap push down the top cap and at the same time pull up the inner tube to prevent uncontrolled release.

3

Use a 14 mm wrench and a 13/16" open end wrench to loosen and remove the top cap from the shaft.

4

Remove the main spring.

5

Drain the fork leg from oil.

6

Use a 6 mm Allen key to remove the bottom screw. Make sure not to lose the washer.

7

Remove the cartridge from the fork leg.

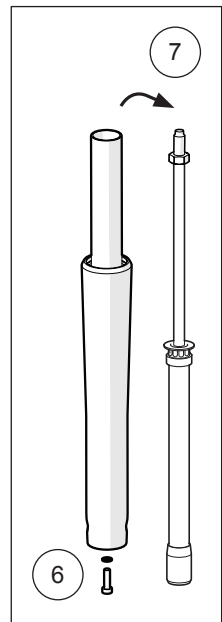
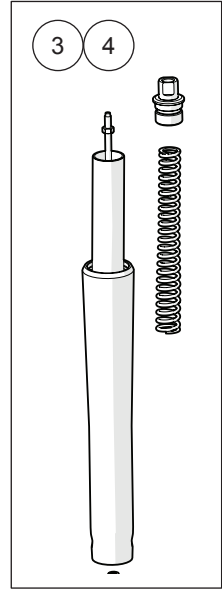
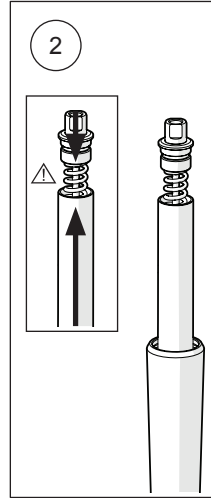

MOUNTING INSTRUCTIONS

8

Use appropriate tool to carefully remove the oil seal clip.

9

Remove the inner tube from the outer tube, refer to the vehicle service manual.

10

Examine the oil seal, bushings and oil seal clip for wear. Replace if needed.

11

Apply oil seal grease according to the vehicle service manual on the oil seal surfaces inside the outer tube, and, on the outside of the oil seal.

12

Put the oil lock sleeve (21802-01) in the outer tube. Make sure to install it correctly.

13

Install the inner tube in the outer tube. Make sure that the inner tube is completely inserted in the outer tube. Make sure that the oil lock sleeve is installed correctly.

14

Install the oil seal and bushing according to the vehicle manual.

15

Install the oil seal clip.

16

Install the top out spring (21801-01) in the fork leg.

Lowering kit 08865-01 only:

Install the spacer (21803-01) (A) and the top out spring (B) in the fork leg.

⚠ Caution!

Make sure to install the spacer and the spring in the correct order.

Lowering kit
08865-01:

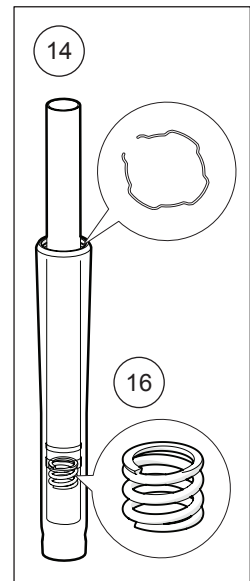
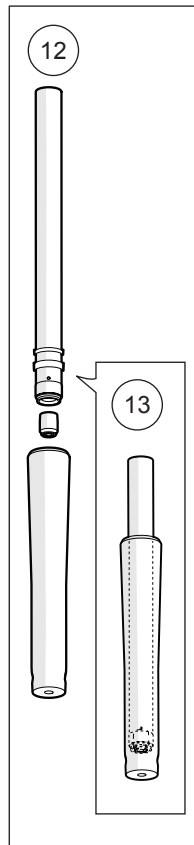
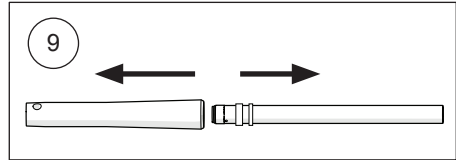
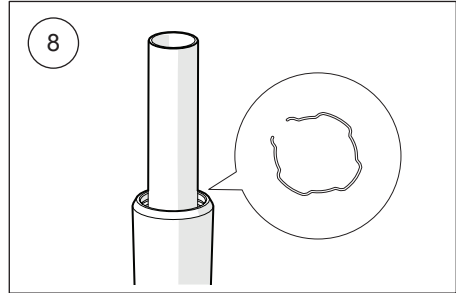
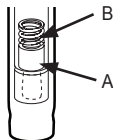

MOUNTING INSTRUCTIONS

Install the Öhlins cartridge kit (all models)

1

Remove the screw top cap, top cap and the guide sleeve external from the shaft.

2

Adjust the shaft nut as far up as possible on the shaft, leave enough threads on the shaft to install the pull up tool.

3

Install the pull up tool (01765-08) on the shaft. Tighten with your hand.

Caution!

Keep the fork leg in a vertical position during the installation procedure.

4

Make sure that the oil lock sleeve is in correct position.

Caution!

Make sure that the guide sleeve internal touches the seal head.

Make sure that the guide sleeve internal is correctly positioned during the installation procedure, steps 5-11.

5

Put the cartridge in the fork leg.

6

Make sure that the cartridge is in bottom position. Apply threadlocker (see the vehicle service manual) on the bottom screw. Insert the washer and the bottom screw. Use a 6 mm Allen key to tighten the bottom screw. Tighten according to the vehicle service manual.

7

Pour approximately 300 ml Öhlins front fork fluid (01309-XX) in the fork leg. If the oil level comes near the upper end of the inner tube, move the steel tube up and down to let out all air from the fork leg.

8

Pull the inner tube up and down approximately 10 times to aerate the fork leg.

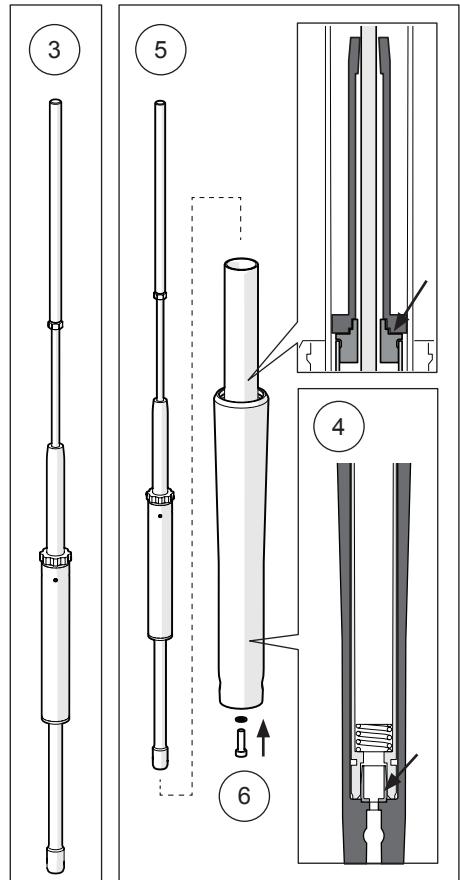
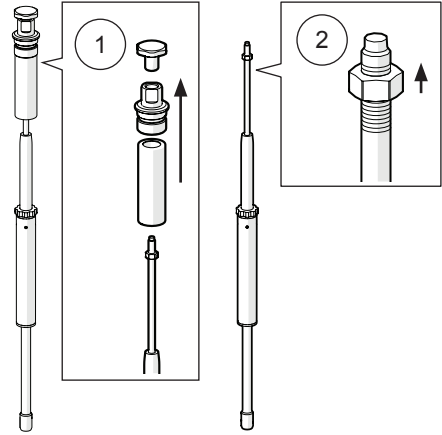

MOUNTING INSTRUCTIONS

9

Pull the shaft up and down approximately 10 times to aerate the cartridge.

10

Make sure that the shaft assembly is in the bottom of the fork leg and that the outer tube is in bottom position. Measure the oil level with a ruler. For recommended oil level, see setup data in this folder.

11

Make sure that the guide sleeve internal is correctly positioned. Make sure that the mark on the main spring is up. Install the main spring over the pull up tool (01765-08).

12

Carefully install the guide sleeve external.

Caution!

The guide sleeve external is easily damaged.

13

Push the spring and the guide sleeve external down, and at the same time pull up the shaft. Carefully insert the stopper plate tool (02810-03) below the shaft nut.

14

Remove the pull up tool from the shaft.

15

Make sure that the stopper plate tool stays in place. Use a 13 mm wrench to adjust the shaft nut until bottomed.

16

Install the top cap on the shaft until stop.

Note!

Make sure that the top cap is completely bottomed.

17

Use a 13/16 open end torque wrench and a 13 mm wrench to tighten the shaft nut to the top cap. Tighten the shaft nut to 15 Nm.

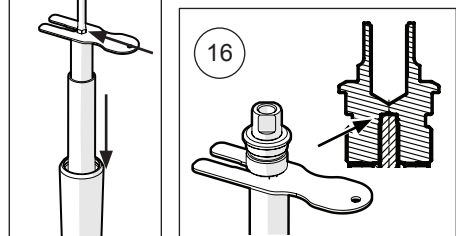
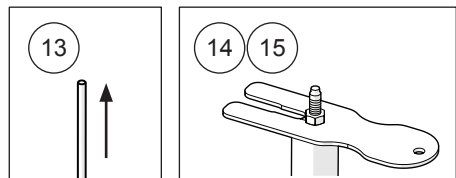
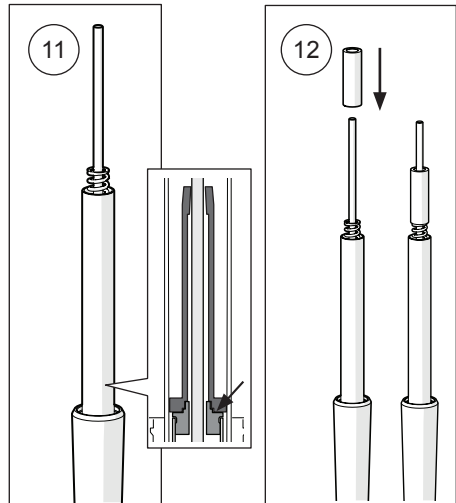
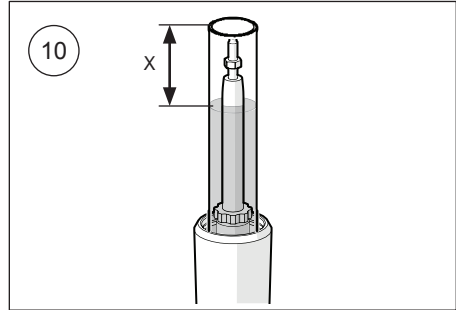

18

Push down the guide sleeve external and carefully remove the stopper plate tool. Make sure not to damage the guide sleeve external.

19

Pull up the inner tube and at the same time push down the top cap. Use a 13/16" open end torque wrench to tighten the top cap to the inner tube. Tighten the top cap, refer to the vehicle service manual.

20

Install the fork legs in the vehicle, refer to the vehicle manual.

⚠ Warning!

Make sure to install all removed parts in the same positions as they were before the installation of the Öhlins cartridge kit.

👁 Note!

After you have installed the cartridge in the fork leg, place the sticker (01185-04) on the top cap.

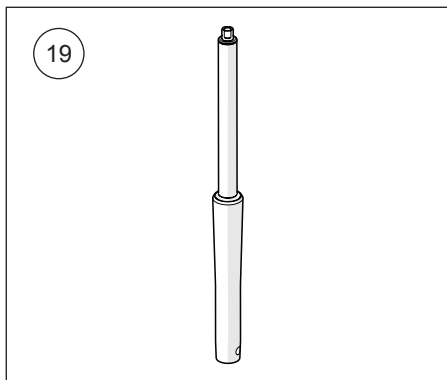

SETUP DATA

Öhlins Front fork fluid	01309-xx	
Recommended oil level	80	mm

SPRING GUIDE

Make sure you choose the correct spring for your rider weight, driving style and preferences. Contact an authorized Öhlins service center for advice.

Ride height	Spring part no	Spring rate N/mm
One driver, no extra load <i>Recommended spring</i>	08419-10	10
Lowering kit 25 mm*	08865-01	13

** For best handling characteristics, we recommend to combine this kit with a lowered rear (12 mm). To lower the rear, contact an authorized Öhlins service center.*

Öhlins products are subject to continuous improvement and development, therefore, although these instructions include the most up-to-date information available at the time of printing, minor updates may occur.

To find the latest information contact an Öhlins distributor. Please contact Öhlins if you have any questions regarding the contents in this document.

Part no. MI_FKC101_1
Issued 2015-08-26

© Öhlins Racing AB. All rights reserved. Any reprinting or unauthorized use without the written permission of Öhlins Racing AB is prohibited.

Öhlins Racing AB
Box 722
S-194 27 Upplands Väsby, Sweden
Phone +46 8 590 025 00
fax +46 8 590 025 80



www.ohlins.com