

HYPERPRO

LOWERING KIT / VERLAGINGSSET

for

KAWASAKI Z 1000 Models '03-'06

LK-KA10-003-30 PART LIST

PR121880 - Pull rods/ trekstangen	2
-	-
-	-
-	-

ALL IDEAS, DESIGNS ARRANGEMENTS AND PLANS INDICATED OR REPRESENTED BY THIS DRAWING ARE OWNED BY HYPERPRO AND WERE CREATED, EVOLVED AND DEVELOPED FOR USE ON AND IN CONNECTION WITH THE SPECIFIC PROJECT. NONE SUCH IDEAS, DESIGNS, ARRANGEMENTS OR PLANS SHALL BE USED BY OR DISCLOSED TO ANY PERSON, FIRM OR CORPORATION FOR ANY PURPOSE WHATSOEVER WITHOUT THE WRITTEN PERMISSION OF HYPERPRO.

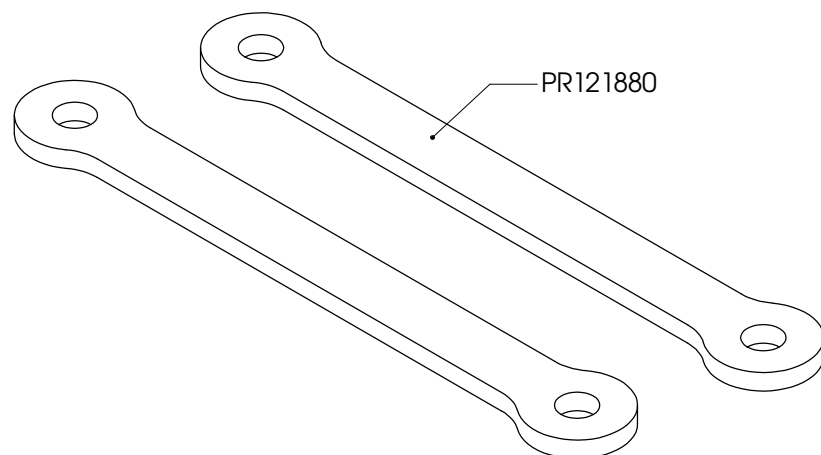

Inbouw handleiding

VOORZIJD

De vorkpoten maximaal 10mm door de bovenste kroonplaat heen steken. De veer-voorspanning minimaal zetten (tegen de klok in draaien). De luchtkamer reduceren als de vork will doorslaan.

ACHTERZIJD

Verwijder de originele trekstangen en de schokdemper. Verminder de veer-voorspanning met 7mm (tegen de klok in draaien). Monteer de schokdemper en de HYPERPRO trekstangen. Het achterwiel eerst belasten voordat de link vastgezet word.

LET OP! DE LENGTE VAN DE ZIJSTANDAARD MOET 15-20mm INGEKORT WORDEN.

Instruction manual

FRONT

Mount the fork legs max 10mm through the triple clamp. Turn the preload adjuster to minimum preload (counter clockwise). Reduce the air chamber in the fork if the fork hits the end of its stroke.

REAR

Remove the original pull rods and the shock. Reduce the spring preload by 7mm (turn counter clockwise). Install the shock and the HYPERPRO lowering pull rods. Put some pressure on the rear wheel before tightening the link.

WARNING! SHORTEN THE SIDE-STAND 15-20mm.

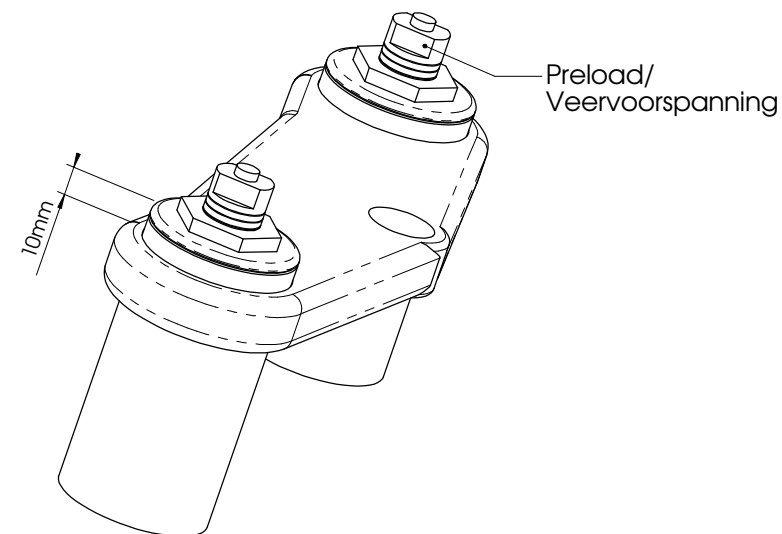

See WWW.HYPERPRO.COM for more info about our products.